

Vantage Series 4000 Strap On Sensor Installation- Zee Shot

The following is an instruction on installing the strap on sensor for the Vantage Series 4000.

There are two styles of strap on sensors. One is referred to as Small Strap On sensor (used on pipe sizes 1”-8”) the other is the Large Strap On sensor (used on pipe sizes 4”-120”). The Zee Shot sensor speedrails will accommodate both the Small and Large sensors so the mounting configurations will be the same for either sensor. It is important to note, however, that the electronics unit will need to be programmed for the specific sensor used.

Where do I place my sensors in relation to upstream and downstream conditions?

The ultrasonic transit time flow meter accuracies are based upon well developed velocity profiles. Upstream disturbances such as pumps or tees and elbows will effect the velocity profile. Below is a recommended straight runs to assure meter accuracies.

| Device | Upstream from meter(in pipe diameters) | Downstream from meter(in pipe diameters) |
|-----------------------|--|--|
| Tees & Elbows | 10-15 | 2-3 |
| Reducers | 10 | 2-3 |
| Increases | 20 | 2-3 |
| Valves (fully opened) | 10-15 | 2-3 |
| Valves (modulating) | 20-25 | 2-3 |
| Pumps | 20-25 | 2-3 |

In vertical runs, the flow should always be flowing up and never down.

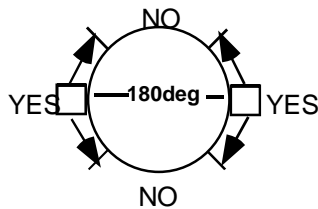

The sensor/speedrails should always be placed on the side of the pipe as Shown on the left and never on the top or the bottom of the pipe.

Note:
Cast or Ductile Pipe

Sand pipe to a smooth surface under sensor face

1

Note:
Asbestos Cement Pipe

Place coat of shellac on pipe surface under sensor face

2

Sensor #1=Upstream
Sensor #2=Downstream

X Stand Here to perform Sensor #1 Installation

3 (Top View)

Place rail for Sensor #1 on pipe

4

Attach chains to hook

5

Rotate Speedrail toward you to the center of the pipe.

6

Use level on side of Speedrail to locate center pipe position

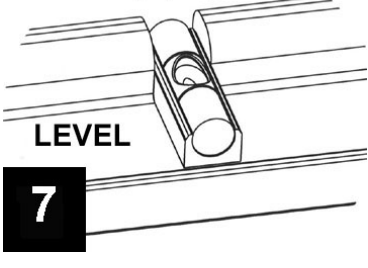

Finger tighten chains with wingnuts



Place bead of silicone grease on face of Sensor #1

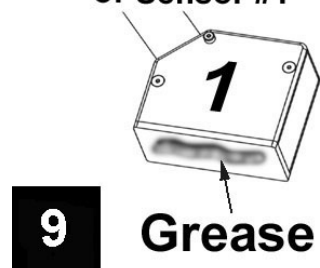

Insert Sensor #1 with nipple pointing to your right (upstream)

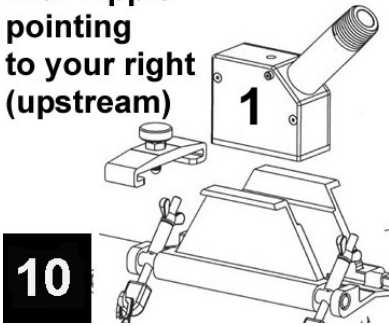

Slide clamp over center of sensor

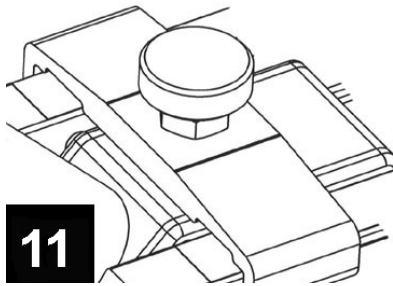

Secure tightly with thumbscrew and lock with jam nut

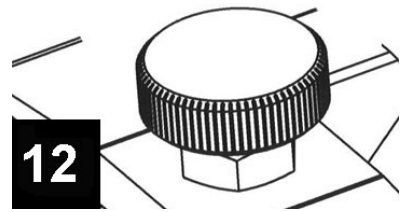

Z-Shot Locator

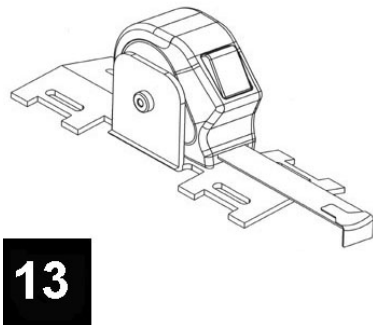

Hook locator tape measure to edge of sensor

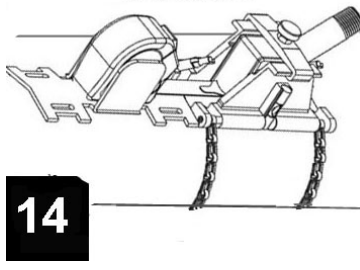

Pull tape measure until it reads correct distance (X)

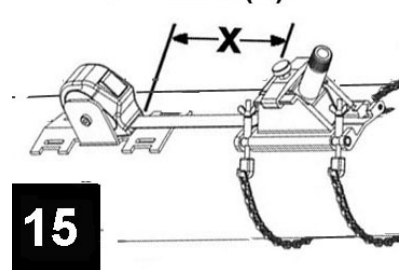

Secure Z-Shot locator with velcro straps

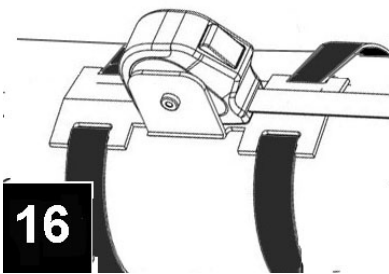

Align 2nd sensor holder with velcro straps at 180deg (use level)

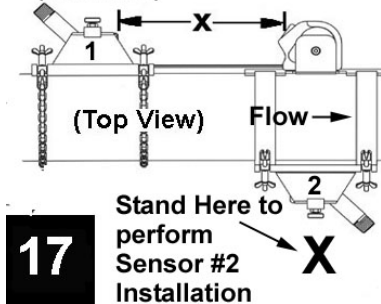

Place a Mark at each end of the Speedrail. Remove Zshot Locator.

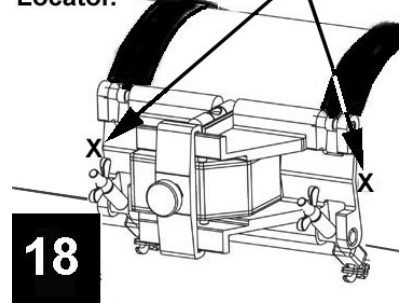

Place rail for
Sensor #2 on pipe

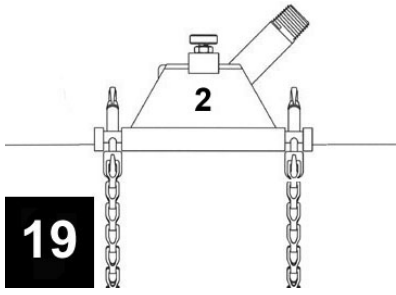

19

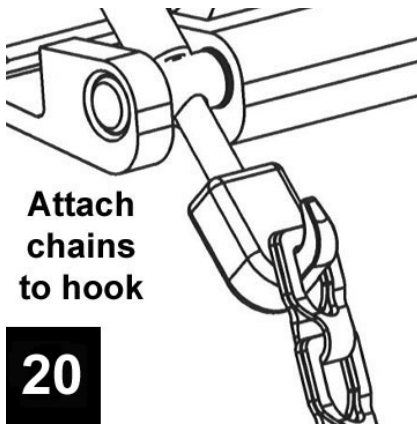

Attach
chains
to hook

20

Rotate Speedrail #2 to the
centerline of the pipe and align
with Marks Previously made.

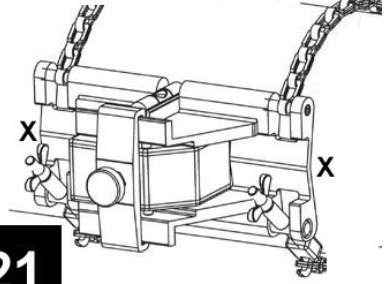

21

Use level on side of
Speedrail to locate
center pipe position

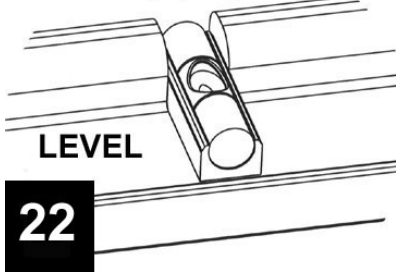

22

Finger tighten chains
with wingnuts



23

Place bead of silicone
grease on face
Sensor #2



24

Grease

Insert Sensor #2
with nipple
pointing
to your right
(Downstream)

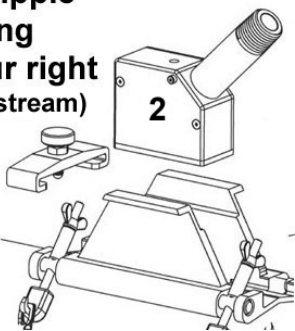

25

Slide clamp over
center of sensor

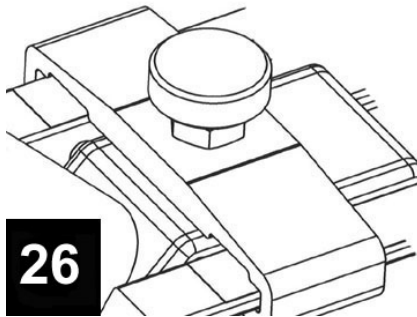

26

Secure tightly with
thumbscrew and
lock with jam nut

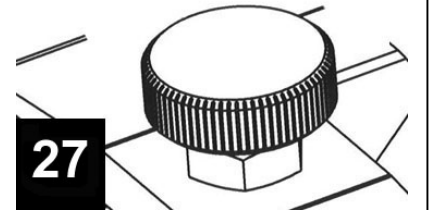

27

Attach conduit to
each sensor

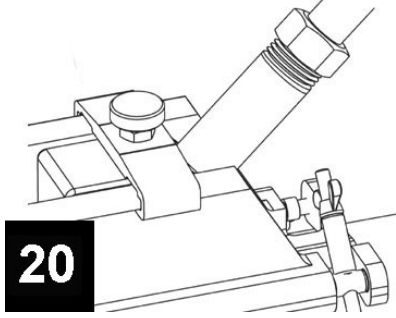

20

Refer to the Manual for wiring of sensor cables into electronics.