

# VANTAGE<sup>®</sup> 2200

**A NEW OPEN CHANNEL FLOW AND LEVEL METER  
THAT CAN PAY FOR ITSELF IN ONE WEEK**



ACCURACY 0.02"

**Eastech Badger**  
ULTRASONIC FLOW MEASUREMENT 

# VANTAGE® 2200

## EASTECH BADGER COMBINES FLOW MEASUREMENT, LEVEL TRANSMISSION AND DATA LOGGING WITH IEEE 754 PRECISION ACCURACY AND 5 MINUTE PROGRAMMING.

The Vantage 2200 is an advanced microprocessor-based ultrasonic transmitter utilized for extremely accurate measurement of both liquid level and flow in open channels. Each unit is equipped with an internal data logger that provides for on-screen display of maximum, minimum and average daily flows. More than 70 standard flow equations for flumes, weirs and open flow nozzles are stored in non-volatile memory. Dual sensors can be input to a single set of electronics for dual weir/flume or bar screen level applications. The Vantage 2200 is designed to be extremely user-friendly with an easy to read 20 character alphanumeric, self-prompting display and a menu-driven programming guide available in English, Spanish and German.

## FLOW

The Vantage 2200 is pre-programmed at the factory for specific customer applications. If on-site calibration is required, more than 70 standard flow equations for flumes, weirs and open flow nozzles are stored in non-volatile memory. For non-standard applications, a site specific H/Q table may be entered through the 16 button keypad.



## LEVEL

When utilized strictly for level measurement, the Vantage 2200 will accurately measure fluid levels in ranges up to 50 feet. Initial programming is simply accomplished through self-prompting displays assisted by menu-driven programming guides.

### APPLICATIONS

- ▶ Plant Influent
- ▶ Plant Effluent
- ▶ Dual Channel Measurement

The FB2 and FB4 sensor heads are both capable of withstanding indefinite submersion. The transmitter portion of the 2200 is FM approved for Nema 4, 4X, Class I, Division 2 nonincendive hazardous environments and is equipped as standard with an integrated data logger. Flow data may be accessed through a comprehensive selection of electronic outputs: 4-20mA, programmable relays, RS232 / 485, Modbus®, Profibus® and DeviceNet®.



### APPLICATIONS

- Level Measurement ◀
- Differential Level Measurement ◀
- Dual Channel Measurement ◀
- Pump Alternation ◀

FM certified for hazardous service, sensing heads are available in Tefzel®, PVC or glass-filled polyester epoxy and are accurate to within  $\pm 0.02$  inches. Both the sensing and transmitter portion of the Vantage 2200 are warrantied for a period of 3 years. Each unit is equipped with gas discharge arrestors and EMI/RFI filtering to prevent failure due to lightning and power surges.

# ACCURACY 0.02"

## The Open Channel Flowmeter that can pay for itself in one week

The overall accuracy of an ultrasonic open channel flowmeter is dependent upon conversion of level measurement to flow. The more accurate the conversion, the more accurate the flow data. **A 10% error in level measurement can result in a 25% error in flow measurement.**

**Since the Vantage 2200 employs IEEE 754 single floating point precision in all of its computations, an error of less than 0.0000005% is introduced during the level to flow conversion.**

When billing customers for treatment services, the accuracy of the flow information obtained directly translates into dollars. Since level accuracy statements from most open channel flowmeter manufacturers will vary from .02" to .25", it is extremely important to study these statements in order to determine the best suited product for the intended application.

### COMPARATIVE COST ANALYSIS (0.25" vs 0.02")

18" PARSHALL FLUME WITH 3" HEAD RISE	
$Q = K \times H^{(X)}$ <small>FLOW                      COEFFICIENT FACTOR                      HEAD RISE (ft)</small>	
<b>FLOWMETER Accuracy: 0.25 inches</b>	<b>VANTAGE 2200 Accuracy: 0.02 inches</b>
$Q = K \times H^{(X)}$ $Q = 6 \times 0.229^{(1.538)}$ $Q = 0.6258 \text{ cu. ft./sec.}$ $Q = 281 \text{ GPM}$	$Q = K \times H^{(X)}$ $Q = 6 \times 0.248^{(1.538)}$ $Q = 0.7044 \text{ cu. ft./sec.}$ $Q = 316 \text{ GPM}$
<b>A Level Error of 0.25" (8.3%) Results in a 12.5% Flow Error</b>	<b>A Level Error of 0.02" (0.67%) Results in a 1.25% Flow Error</b>

At the national average billing rate of \$2.61/1000 gal., an 11.25% (12.5% - 1.25%) flow error differential in a 1MGD plant translates to 112,500 gallons/day or 787,500 gallons/week of unbilled revenue (\$2,055/week). The higher accuracy of the Vantage 2200 has the potential to pay for itself within the first week of operation while adding \$106,880/year to the plant's revenue stream.

As can be seen from the tables below, a 10% error in level measurement can result in a 25% error in flow measurement. The tables also verify that a meter with an accuracy statement of 0.25 inches will not provide the needed accuracy for billing or NPDES permit requirements—especially when coupled with normally accepted flume and weir accuracies of 3 to 5%.

#### 18 Inch Parshall Flume

Flume Head Rise	Accuracy 0.02 inches		Accuracy 0.04 inches		Accuracy 0.25 inches	
	Level Error	Flow Error	Level Error	Flow Error	Level Error	Flow Error
3 inches	0.67%	1.25%	1.3%	2.9%	8.3%	12.5%
6 inches	0.33%	0.54%	0.67%	1.0%	4.15%	6.26%
9 inches	0.22%	0.35%	0.44%	0.69%	2.05%	4.16%

#### 60 Degree V-Notch Weir

Weir Head Rise	Accuracy 0.02 inches		Accuracy 0.04 inches		Accuracy 0.25 inches	
	Level Error	Flow Error	Level Error	Flow Error	Level Error	Flow Error
2 inches	1.0%	3.59%	2.0%	5.19%	12.5%	32.8%
4 inches	0.5%	1.25%	1.0%	2.5%	6.25%	15.6%
8 inches	0.25%	0.64%	0.5%	1.28%	3.13%	7.66%

# APPLICATIONS

## FLOW & LEVEL



The FM approved electronics of the 2200 is extremely versatile and can be programmed for flow (using weirs/flumes or any special H/Q function) or level measurement of up to 50 feet. Three sensors are available. The FB2 and FB4 sensors are capable of measuring flow or level from 0-25 feet. The FB3 is a glass-filled polyester sensor with an extended level range of 0-50 feet.

### FLOW

The following is a partial list of the stored flow to primary element functions.

- ▶ Parshall flumes
- ▶ Manhole flumes
- ▶ Palmer Bowlus flumes
- ▶ Trapezoidal flumes
- ▶ H flumes
- ▶ V Notch weirs
- ▶ Contracted weirs
- ▶ Suppressed weirs
- ▶ Cipoletti weirs
- ▶ Open flow nozzles
- ▶ Kennison nozzles
- ▶ Mannings circular
- ▶ Mannings rectangular
- ▶ Special H/Q

### LEVEL

Level measurement can be programmed in the 2200 for a range of 0-50 feet. Vertical rectangular and cylindrical or horizontal cylindrical vessels are typical applications.

## DUAL SENSORS



Dual sensors may be used with the Vantage 2200 electronics. Individual display functions are provided for each sensor. This allows for two separate measurements within a single meter.

### Typical arrangements are:

#### Dual Sensors

Dual weirs or flumes or flow for flume/weir and level. Sensors may be programmed identically or with different calibration variables.

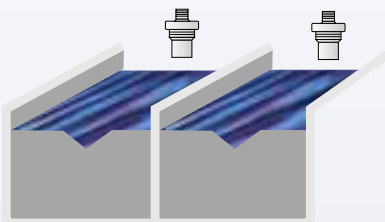

#### Bar Screen Level Differential

This will alert the operator to a clogged bar screen through the use of a specific alarm assigned to one of the relays. The difference between level 1 and level 2 will be displayed.

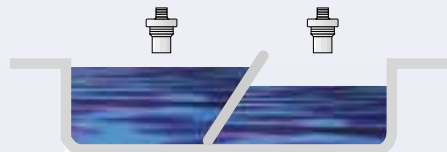

#### Compound Weirs

Programming dual sensors for a compound weir will allow for greater accuracy over the entire flow range.

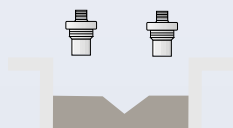

## PUMP ALTERNATION

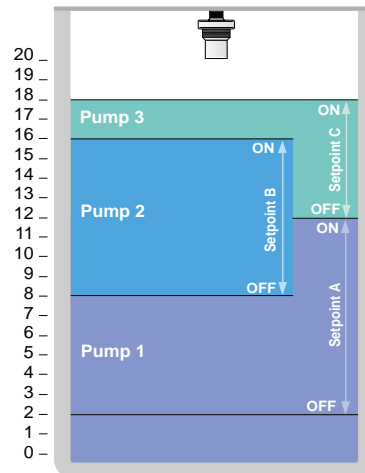

The pump alternation feature of the Vantage 2200 is utilized when the treatment facility has more than two pumps that are to be actuated based upon level set points.

**For example:** a sewer line will feed into a wet well at a lift station. The station employs three pumps. The wet well is 20 feet deep. As the wet well fills, the operator wants to turn on the pump (Pump 1) when the level reaches 12 feet and off at 2 feet. If the level in the well continues to rise with only one pump running, the operator will probably require the second pump (Pump 2) to come on at a level of 16 feet and off at 8 feet. If the level in the well continues to rise with both pumps running, the operator will initiate a third pump (Pump 3) to come on at a level of 18 feet and off at 12 feet.

There are three setpoints: on at 12 feet, off at 2 feet (Setpoint A); on at 16 feet, off at 8 feet (Setpoint B); on at 18 feet, off at 12 feet (Setpoint C).

With the pump alternation feature, the setpoints in the 2200 are not assigned to a specific relay controlling a specific pump. The 2200 tracks each time a relay is activated, and when a setpoint is reached, the relay with the least number of activations is tripped. **WITH THIS FEATURE, ALL THREE PUMPS WILL EXPERIENCE EVEN WEAR.**

The pump alternation feature may also be employed on filling applications—such as a water tank fed by multiple pumps.

## PROGRAMMING

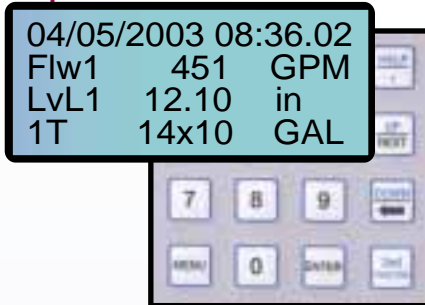

### 5 Minute Field Programming

The Vantage 2200 utilizes a self-prompting display that allows for 5 minute programming of standard applications and 15 minute programming of in-depth data logging applications and auxiliary outputs. The menu driven programming feature allows the user to read the display status, log values, and calibrate the 2200 with a drill down type menu structure in English, Spanish and German.

Up to 78 primary element functions for weirs and flumes are stored by size and name with the added capability of entering special H/Q curves by flow (in engineering units). All flow calculations are displayed as actual primary elements, not as power function. Mounting dimensions for the sensor are displayed for each application.

The microprocessor-based electronics can be programmed to allow customer selection of tank shape or flow functions. The following is standard: Parshall flume, Manhole™ flume, Lagco flume, V-Notch weir, open flow nozzle as well as Manning's equation. Special flumes can be programmed in the field by following a simple setup procedure.

A 16 button keypad drives the menu section. Outputs are 4-20 mA, 5 programmable relays, RS-232 serial port (allows for real-time communications operations in a Modbus® protocol) and a separate RS-485 port. Profibus® and DeviceNet® communication protocols are also available.

Flash memory is employed for logging flow data. Data is retrieved by viewing the local display or downloaded via the serial port.

## DATA LOGGING



The Vantage 2200 has a 256K Byte logger with storage intervals. The logger can be programmed for various time intervals. Up to 8 channels can be logged, including flow, level setpoints, and totals for one or two sensors.

### Daily Averages

Daily summary allows viewing of the previous eight days. This includes times, dates, averages, minimums, maximums and totals.

### Logger Graph

In addition, a bar graph may be visually displayed on the 2200. The graph will display the stored logger data in pre-programmed time intervals.

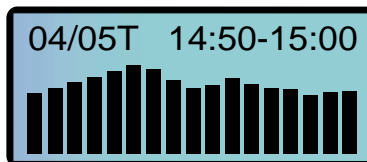

### Data Retrieval

Logger data can be collected by using a laptop computer, an optional modem installed in the 2200 enclosure or by the Palm PDA data collection module (see page 6). The Palm III may be utilized for downloading of all data from the 2200 logger. Just purchase a standard Palm III and download free software from the Eastech Badger website (available 9/01).



## INFORMATION DISPLAY

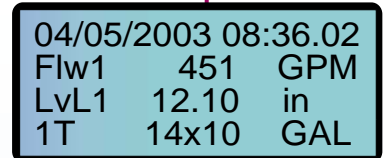

Page 1

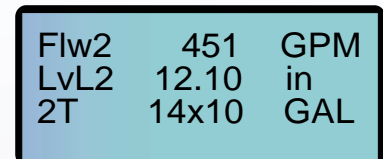

Page 2

The Vantage 2200 utilizes a 20 character four line backlit display. The main screen can be programmed to display up to eight lines of meter information such as flow 1 and/or flow 2 (for dual sensors), totals 1 and/or totals 2 (for dual sensors), level 1 and/or level 2 (for dual sensors), time, date and relay alarms. The order of display line information is programmed to user preference. The backlit display may be programmed to be ON or OFF, or to remain OFF during a selected time interval. Display contrast is fully adjustable.

The 2200 will display proper mounting distances for all programmed primary devices. Diagnostic information is retrieved via a menu-driven self-test program capable of isolating fault parameters such as: loss of signal, 4-20 mA loop failure, logger memory full, communications error, sensor fault and open transmitter cable connection.

# DATA TRANSFER

## MULTIPLE OUTPUTS

The Vantage 2200 is designed for reliable and accurate retrieval of data—either on-site or remotely. The unit is equipped, as standard, with an integrated data logger capable of storing large amounts of information for later analysis. Because of its multiple output capability, this information may simply be retrieved through the use of one of the following methods.

## CURRENT OUTPUT

4-20 mA. Isolated, 1000 ohms maximum.

## RELAY OUTPUTS

Five SPDT relays available for alarm conditions.

### Relay assignments include:

- ▶ Setpoints: 1, 2 or 3; On and Off selectable for High or Low alarms.
- ▶ Lost signal: used when the sensor does not receive a signal.
- ▶ 4-20 mA Loop: The 4-20 circuit is monitored to detect open circuits.
- ▶ Overrange 1: Maximum level is exceeded.
- ▶ Overrange 2: Identical to overrange 1 for an optional second sensor.
- ▶ Contact Integrator: Assignable to multiplied values in order to pace external equipment.

- ▶ 4-20 mA
- ▶ 5 SPDT Relays
- ▶ RS232
- ▶ RS485
- ▶ Profibus
- ▶ DeviceNet



## SERIAL OUTPUTS

**RS-232:** With Modbus protocol. Flow control is CTS/RTS or none. DB-9 connection.

**RS-485:** With Modbus protocol, Opto-Isolated. Terminal strip connection. The RS-232 & RS-485 can be set with different slave I.D.s.

**Data Logging:** Eight distinct channels are available to log. The storage capacity for a single channel @ 5 minute intervals is 113 days. IEEE floating point storage is used.

## COMMUNICATION PROTOCOLS

**Modbus<sup>®</sup>, Profibus<sup>®</sup> or DeviceNet<sup>®</sup>**

## REMOTE DATA RETRIEVAL

The Vantage 2200 has a built in data logger capable of capturing and storing large amounts of information. The challenge has always been to transfer data efficiently and economically to a central location for analysis. The 2200 is designed for fast and user-friendly retrieval of data by two distinct methods.

### METHOD 1

The new Eastech Badger DCM data collection system allows plant operating personnel the ability to simply download logger data through the use of a standard Palm PDA or laptop. This information can then be transferred to a PC. Free operating software may be downloaded from the Eastech Badger website.

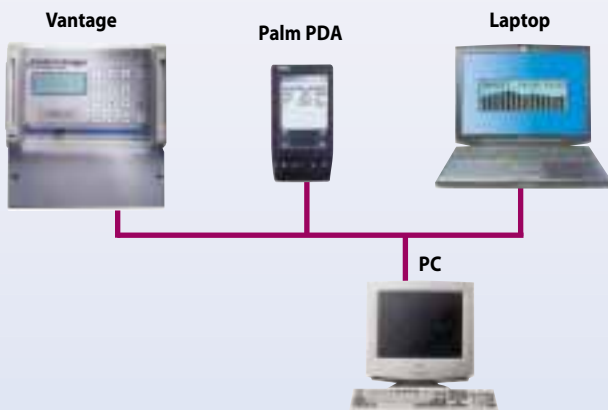

### METHOD 2

A modem is installed within the enclosure of the 2200 for phone line or wireless transfer of data to a central location. Since the Vantage has two totally independent communications ports (RS-232 and RS-485), a single modem can provide data for multiple meters communicating serially through a field network such as Modbus.

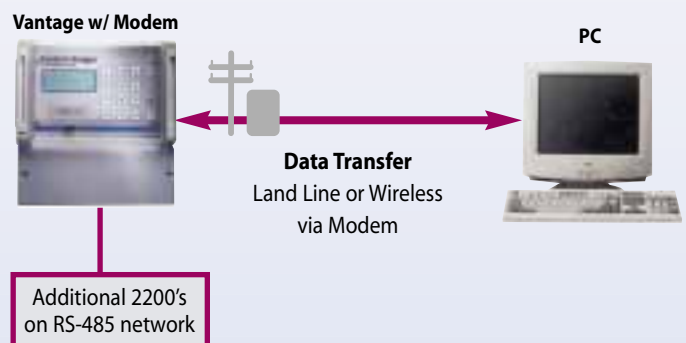

# SPECIFICATIONS

## Dimensions (inches/mm)

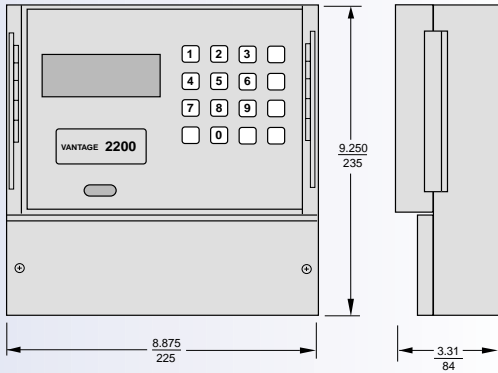

## Wiring Schematic

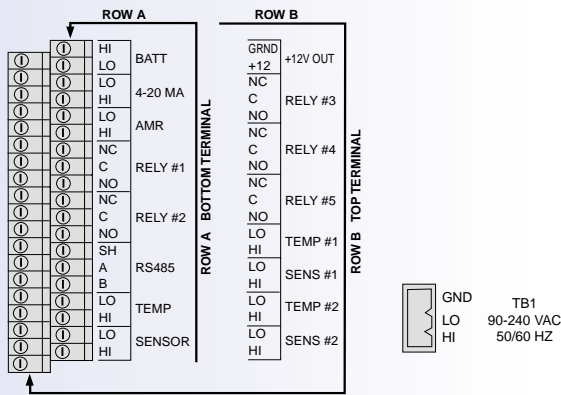

## METER 3 YEAR WARRANTY

ENCLOSURE	
Standard	IP66 / Nema 4X polycarbonate enclosure FM approved nonincendive, Class I, II, Div. 2
Optional	Explosionproof, Aluminum Enclosure Class I, Grps. C & D, Class II, Grps. E, F, G, Div. 1 & 2
Accessories	Heater and thermostat, Door Lock
TEMPERATURE	
Standard	-4° to 158°F (-20 to 70°C)
With Heater	-40° to 158°F (-40 to 70°C)
OUTPUTS	
(1) 4-20 mA (2210)	Analog isolated into 1000 ohms max, monitored to detect open circuits. RFI and gas discharge surge protection and two fuses.
(2) 4-20 mA (2220)	
Relay Alarms	Max. Five SPDT relays (pluggable) 0.25A @ 120 VAC or 0.50A @ 24 VDC
RS-232 Serial Port	1200-38400 Baud, Modbus RTU (2210/2220)
RS-485 Serial Port	Optically isolated, Modbus RTU (2220)
Network Protocols	Modbus, Profibus or DeviceNet
DC Power Out	12 VDC, 100mA maximum
DISPLAY	
Backlit LCD	4 Line x 20 character (contrast control)
POWER	
Wattage	12
Voltage	80/240 VAC, 50/60 Hz / 12-28VDC @ 150 mA.
DATA LOGGING	
Non-volatile flash memory, storage of up to 32768 records.	

## Dimensions (inches/mm)

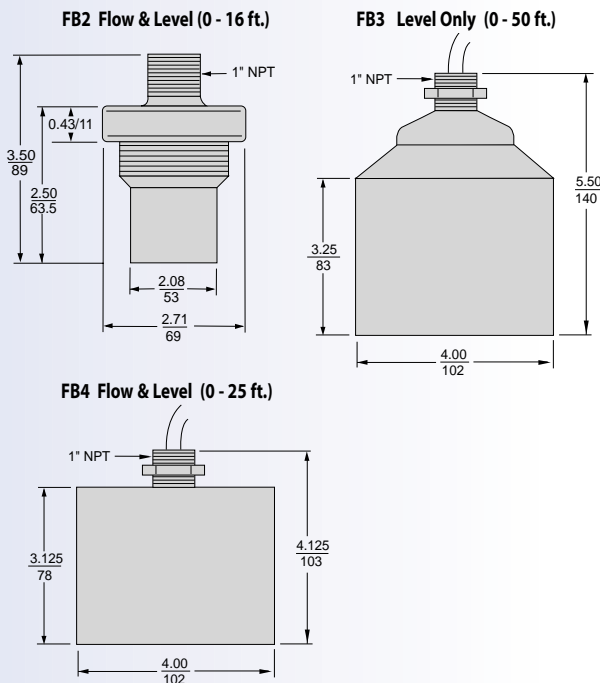

## SENSORS 3 YEAR WARRANTY

FB2/FB4	
Applications	Flow, Level and Chemical Tanks
Certification	FM, Class I, Div. 1, Groups A, B, C, D. (pending)
Sensor	Temperature compensated
Body & Topworks	(FB2) Tefzel® (FB4) PVC
Span Range	FB2 - 0-16 feet max. w/ 12 inch min. offset FB4 - 0-25 feet max. w/ 12 inch min. offset
Temperature	-40° to 158°F (-40° to 70°C)
Mounting	1" NPT nipple and 2" conn. threads (FB2 only)
Accuracy	± 0.02" or ± 0.05% of target distance.
Cable	30 feet
FB3	
Applications	Level Measurement
Certification	FM, Nonincendive: Class I, Groups A, B, C, D, Div. 2
Sensor	Temperature compensated.
Body & Face	Glass filled polyester epoxy
Span Range	0-50 feet max. w/ 24 inch minimum offset
Temperature	-40° to 158°F (-40° to 70°C)
Mounting	1" NPT nipple
Accuracy	± 0.1" or ± 0.1% of span
Cable	100 feet

# SUGGESTED SPECIFICATION

## VANTAGE 2200

An ultrasonic microprocessor-based flow/level meter shall be installed at the location on the plans in accordance with the manufacturer's recommendation. The \_\_\_\_\_ (flow/level) meter shall be programmed for a \_\_\_\_\_ (size & type of primary element or tank type) and scale at maximum to \_\_\_\_\_ (max flow and engineering units or maximum level). The ultrasonic unit shall have the following features:

**Enclosure:** IP66/NEMA 4X, FM approved, Class I, Groups A, B, C & D, Division 2

(optional: Explosionproof, Class I, Groups C & D, Class II, Groups E, F & G, Divisions 1 & 2)

**Power:** 80/240 VAC, 50/60 Hz or 12-28 VDC @ 150 mA with surge suppression and fuse.

**Outputs:** 4-20 mA isolated into 1000 ohms, monitored to detect open circuits, with RFI and gas discharge surge protection and two fuses.

**Relays:** A maximum of 5 relays rated at 0.25A @ 120 VAC or 0.5 A @ 24 VDC. The relays must be assignable by the front panel keypad for up to three setpoints, loss of signal, 4-20 loop, overrange 1, overrange 2, contact integrator or pump alternation.

**Data Logger:** There shall be a data logger integral to the electronics. The data logger shall have non-volatile flash memory with a storage capacity of 32768 records. Software shall be supplied for downloading the data. The logged data shall have the capability to be displayed on the backlit display in graphing form for daily minimum, maximum, average and total flow units for the past eight days.

**RS-232:** There shall be a RS-232 serial port of 1200-38400 baud, Modbus RTU protocol.

**RS-485:** There shall be a RS-485 serial port optically isolated, Modbus RTU protocol.

**Electronics:** The display for the electronics must be a four line, 20 character display with the ability to turn the display On or Off by the front panel keypad and also to adjust the contrast. The meter must employ a menu-driven programming style of data entry. All programming functions and data entry and collection shall be initiated by the display and the 16 button keypad. At least 78 flow curve calculations shall be stored in the firmware with the ability to produce special curves either via flow equations or head vs flow tables.

The unit shall compute all flow calculations using IEEE 754 single floating point precision. Units using flow lookup tables for standard flume or weir equations shall not be permitted. The electronics shall be able to accept up to two separate sensors and display all functions for both channels.

**Warranty:** The electronics and sensor shall carry a 3-year warranty.

## SENSORS

**Flow/Level (0-16 ft) or (0-25 ft):** The sensor shall be designed for flow or level and designed for use in Class I, Division 1, Groups A, B, C & D hazardous areas. The sensor shall be made of Tefzel® or PVC and be supplied with 30 feet of cable. 1000 ft. maximum cable runs allowed. Splices shall be made waterproof. The maximum level range of the sensor shall be 16 feet or 25 feet.

**Level (0-50 ft):** The sensor shall be designed for levels up to a maximum of 50 ft. and designed for use in Class I, Division 2, Groups A, B, C & D hazardous areas. The sensor shall be made of glass filled polyester and be supplied with 100 ft. of cable. 300 ft. maximum cable runs allowed. Splices shall be made water proof.







**Sensor Accuracy:** The sensor shall be accurate to 0.02 inches or 0.05% of target distance.

The sensor cables shall be run in dedicated conduit.

The unit shall be a Model 2210/2220 as manufactured by Eastech Badger, Tulsa OK or equal.

## Ordering Guide

Please provide the following information: Size and type primary element: \_\_\_\_\_ Maximum flow: \_\_\_\_\_ Maximum level: \_\_\_\_\_

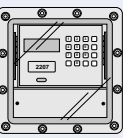
Enclosure	Sensor	Extra Cable	Options	Data Retrieval	Manhole Flume
<b>2210</b> Nema 4, 4x, Nonincendive, Class I, Division 2 One 4-20mA, Data logger, RS232 <b>Same-Day Shipment</b>   	<b>FB4A</b> Flow/Level (0-25 ft) PVC (30' cable)	_____ ft.	Factory Calibrated <b>A</b>	Palm Interface Cable <b>P</b>	4" <b>MF4</b>
<b>2220</b> Nema 4, 4x, Nonincendive, Class I, Division 2 Two 4-20mA, Data logger, RS232/485 <b>Same-Day Shipment</b>   	<b>FB2A</b> Flow/Level (0-16 ft) Tefzel (30' cable)		Heater & Thermostat <b>B</b>	Modem (phone line) <b>M</b>	6" <b>MF6</b>
<b>2207</b> Explosionproof, Class I, Groups C & D, Division 1 & 2  	<b>FB3A</b> Level (0-50 ft) FM, Class I, Div. 2 Polyester (100' cable)		Keylock <b>C</b>	Splice Kit <b>D</b>	Profibus <b>E</b>
			Relay Kit* <b>R</b>	DeviceNet <b>F</b>	10" <b>MF10</b>
					12" <b>MF12</b>

\* Relays are not included as standard. Please specify amount required.

Ordering Example: Vantage 2210 with 0-25' sensor, factory calibration, heater and therm, 2 relays. **2210FB4AABR2**