

SCOPE

This manual contains information concerning the installation, operation and maintenance of the Vantage 4000. To ensure proper performance of the unit, the instructions should be thoroughly understood and followed.

Keep the manual in a readily accessible location for future reference.

Changes and additions to the original edition of this manual will be covered by a “CHANGE NOTICE” supplied with the manual. The change notice will identify the sections in this manual where the changes have occurred.

Vantage 4000 Table of Contents

Scope	1-1
General Specifications.....	1-2
Installation Procedure	2-1
Enclosure Mounting	2-1
System Diagram	2-2
Wiring Connections.....	2-3
Splice Procedure.....	2-5
Programming	3-1
QuikCal Menu Functions	3-1
Main Flow Screen	3-2
Review Meter	3-2
Program	3-2
Measure Units	3-2
Sensor Install.....	3-3
Totalizer	3-5
4-20 Output.....	3-6
Damping.....	3-6
Lost Signal.....	3-7
Flow Simulation.....	3-7
Integrator.....	3-7
Setpoints.....	3-8
Relays.....	3-8
Daily Sum	3-8
Data Logger	3-9
System Setup	3-9

GENERAL SPECIFICATIONS

Pipe Size Range	Strap On Sensors: 1" to 120" (Larger pipe ranges available, consult factory) Hotshot Style Sensors: 8" to 120" (using tapping saddles >15") Windowed Spool Sensors: 3" to 48" Internal Wetted Sensors: 12" to 120"
Output	Two 4-20 mADC isolated; 800 ohms max. (Model 4600) One 4-20 mADC isolated, 800 ohms max (Model 4400) Three programmable relays, SPDT .25 amp @ 120 VAC, .5 amp @ 24 VDC (Model 4600) One programmable relay, SPDT .25 amp @ 120 VAC, .5 amp @ 24 VDC (Model 4400) RS-232 Serial Port, 9600 – 36500 Baud, Modbus™ Protocol RS-485 Serial Port optically isolated, Modbus™ Protocol (Model 4600 Only) 12VDC, 100ma Maximum Data Logger & Software CD
Display	Backlit LCD, 128x64 Graphic Module
Programming	Front panel mounted 16 button keypad., Computer or Palm Pilot
Power	80/240 VAC, 50/60 Hz, or 12-28 VDC @ 350 mA continuous.
Accuracy	Up to +/- 0.5% of actual flow above 1 foot per second.
Sensor	<p>Strap On:</p> <p>Temperature Range: -20° to 160° F (-30° to 70° C) -20° to 300° F, High Temperature option</p> <p>Operating Frequency: 640 or 1280 KHz</p> <p>Housing: Anodized aluminum, Ultem plastic</p> <p>Cable: 50 feet of Triaxial PVC coated Std. (1000 ft maximum) Belden 9222 or equal</p> <p>Hotshot Wetted:</p> <p>Temperature Range: -40° to 160° F (-40° to 90° C) 30 kHz</p> <p>Operating Frequency: 640 or 1280 KHz</p> <p>Pressure: 0-300 PSI</p> <p>Housing: 316s/s, PVC tip</p> <p>Cable: 50 feet of Triaxial PVC coated Std (1000 ft maximum) Belden 9222 or equal</p>
Electronic Enclosure	IP66/NEMA 4X standard, temperature range: -4° to 158° F (-20° to 70° C) Optional with heater, temperatures down to -40° F (-40°C)

Installation

Enclosure Mounting

The enclosure is rated IP 66 (NEMA 4X) and can be mounted indoors or out. A sunshade is recommended for outdoor installation. Openings used for the sensor and power must be properly prepared and sealed to maintain the rating. There are two stainless steel mounting brackets factory assembled to the enclosure.

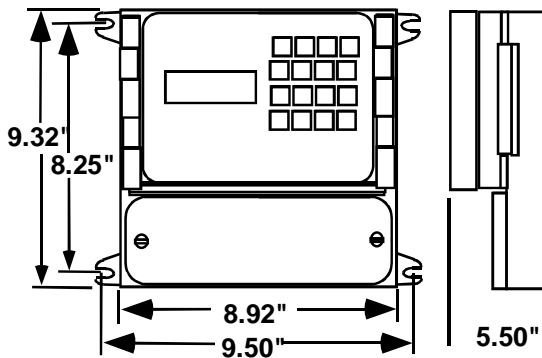

The mounting feet have slots for 1/4" bolts (4 places). The electronics should be mounted with the display at eye level or lower. There are three 1/2" holes in the bottom of the enclosure for conduit fittings. These holes have rubber plugs installed at the factory. If you do not use all three holes for conduit, leave the rubber plugs in the holes to protect the enclosure ratings.

Opening the Enclosure:

There are two hinged door clasps on the front cover of the enclosure. To open, put thumb on one of the hinges, pull toward the outside of the enclosure. Once the hinge pops to the outside it will lower allowing the clasp at the bottom of the hinge to release. Swing the cover towards the front to open. The opposite side will act as a hinge to swing the door freely. To close, clasp the bottom side of the hinge and push the top of the hinge toward the enclosure until it locks.

Hinge Lock and Optional Door Lock

There are two plastic gray plugs supplied with the Vantage 4000. These plugs may be used to permanently disable one side of the hinged handles. If an optional door lock was supplied with the unit then one side of the hinge handle should be plugged and the other side will have the key lock used. Either side hinge handle may be disabled. Insert the gray plug into the keyhole. **Warning: This will permanently disable the hinge handle.** The other side can be used for the key provided for the optional lock.

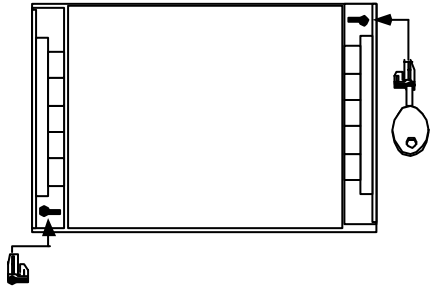

Note: The key will have to be left in the hinge handle if the door is to remain unlocked. The only way the key can be removed is if the hinge handle is locked.

Vantage 4000 Recommended System Diagram

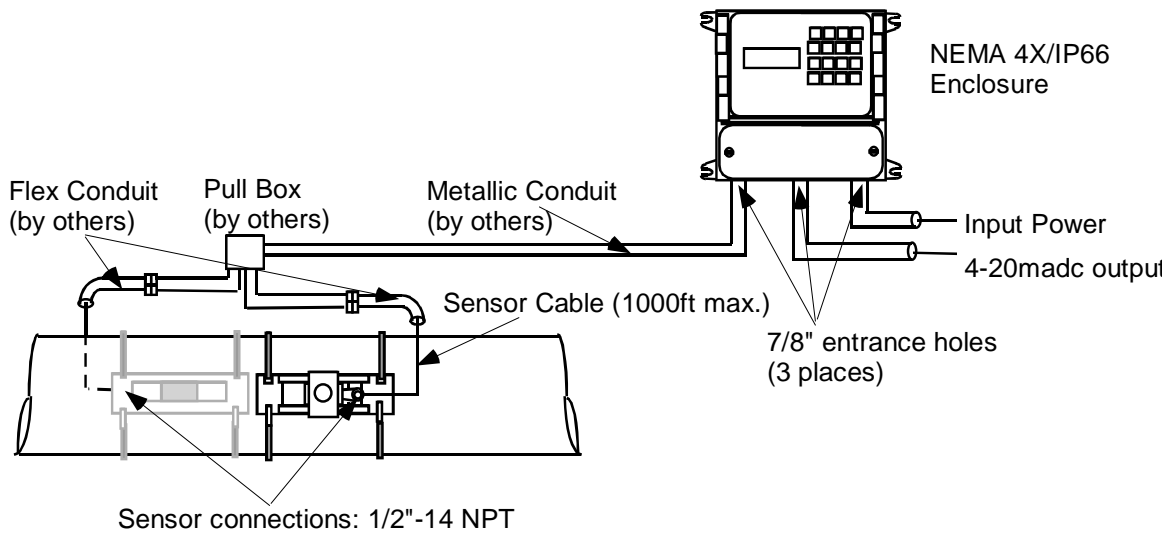

Wiring Diagram

There are three terminal strips provided for all wiring of the Vantage 4000. The AC power terminal is separate from the other two terminal strips. The power terminal strip has three connections for High, Low and Ground for AC voltage only. Refer to the wiring diagram below for all internal wiring connections. The specifications for the load requirements for each input are on Page 1-2 General Specifications. The unit may also be powered with 12-24 VDC at TBA Terminals 14 (+) and 15 (-).

*Model 4600 Only

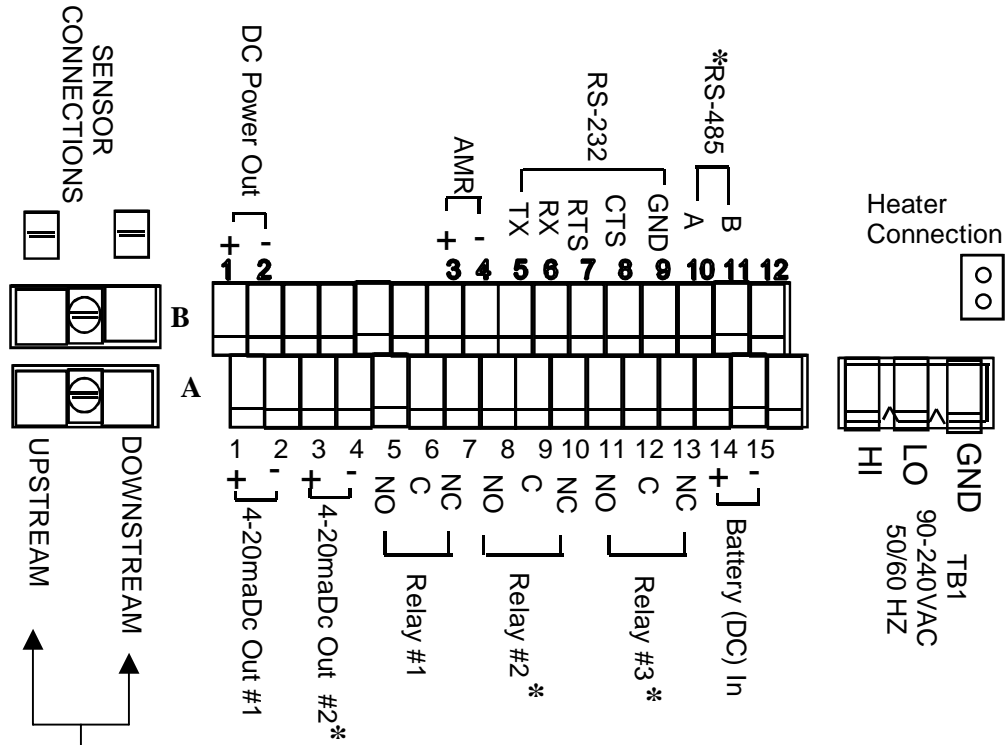

Sensor Cable Preparation

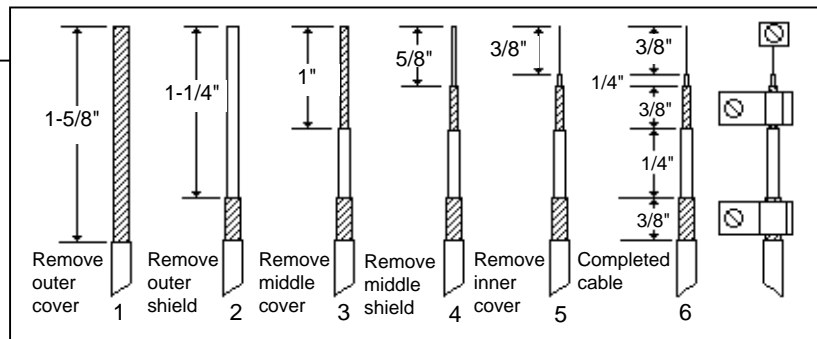

Sensor Cable Preparation

Sensor cable connections. Before pulling the sensor cables through the conduit, mark the ends of the cables to indicate which is the upstream and downstream sensor cable. Leave approximately 8 inches of cable extending from the conduit in the enclosure. Prepare the cable ends in the following manner.

1. Remove outer cable cover. Measure 1-5/8" from the end of the cable. With a cutting tool, carefully cut through the outer covering completely around the cable making sure not to cut into the outer shield. Make another cut from the first cut to the end of the cable and remove the outer cover.
2. Remove outer shield. Measure 1-1/4" from the end of the cable with a pair of small cutters, cut the shield around the cable at the measured point and remove the cut off shield.
3. Remove middle cover. Measure 1" from the end of the cable. With a cutting tool, carefully cut through the middle covering completely around the cable making sure not to cut into the middle shield. Make another cut from the first cut to the end of the cable and remove the middle cover.
4. Remove middle shield. Measure 5/8" from the end of the cable. With a pair of small cutters, cut the shield around the cable at the measured point and remove the cut off shield.
5. Remove inner cover. Measure 3/8" from the end of the cable. With a cutting tool or pair of wire strippers, carefully cut the inner covering completely around the cable, making sure not to cut into the center conductor and remove the inner cover.

After the ends of the cables have been prepared, loosen the screws on the sensor inputs at the lower left corner of the PCB and remove the two pairs of clamps. Take the upstream cable and insert the center conductor into the top terminal of the upstream sensor and tighten the screw. Slightly pull on the cable to ensure the wire is secured to the terminal. Take the downstream cable and insert the center conductor into the top terminal of the downstream sensor and tighten the screw. Slightly pull on the cable to ensure the wire is secured to the terminal.

Place the two pair of clamps over the middle and outer shields and secure them into place. **Verify that the clamps are making good contact with the shields and that no wires of the shields are extending beyond their own clamp down area.**

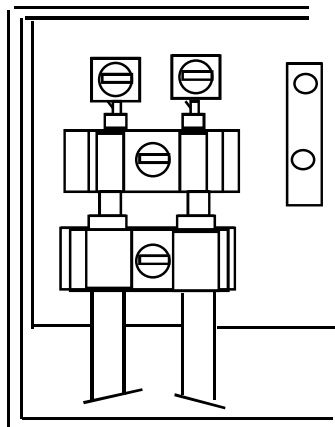

Triax Cable Splice Procedure

Materials Required

- * 4 pigtail cap crimps (wire size 18-12)
 - * 2 center conductor cap crimps (wire size 22-14)
 - * Strips of splice wrap
- Crimp tool (customer supplied)
Knife (customer supplied)
Pointed tool (customer supplied)
Junction box (customer supplied)

A cable connection kit may be purchased through Eastech Badger that will include the * items above (Part # 541874).

Trim each of the four cables at the junction box to 9 inches in length. Each of the four cables can now be prepared as described in the sequence following:

Using a knife, trim two inches of the outer jacket from each cable. The wire braid beneath the outer jacket must not be cut. See "A".

Using a pointed tool, carefully comb out the outer braid of each cable as shown in "B". Form the combed braid into a pigtail dressed to the side of the cable as shown in "C".

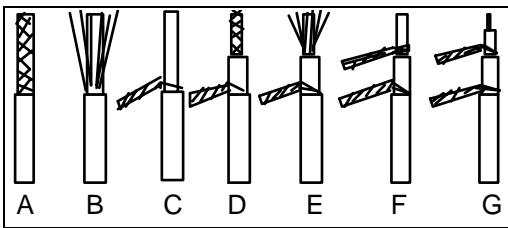

Trim 1 inch of the inner jacket from each of the cables as shown in "D". Again, use care not to cut the inner braid beneath the inner jacket.

Using a pointed tool, carefully comb out the inner braid "E" and form into a pigtail dressed to the same side of the cable as outer pigtail in "F".

Remove 1/2 inch of insulation from the inner conductor of each cable. Cut the outer pigtail to the same length as the inner pigtail on each cable. "G" depicts the completed preparation.

Cable Termination

Pull cables approximately 18 inches outside of junction box. Select one sensor cable and one cable from the electronic enclosure and place them side by side as shown in Fig. 1. Twist each cable's outer pigtails together, then the inner pigtails together and finally the center conductors together to form the cable splice. In similar fashion, connect the remaining sensor cable and the cable from the electronic enclosure.

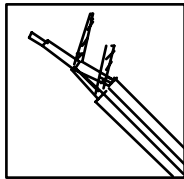

FIG 1

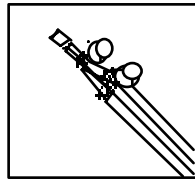

FIG 2

Identification of upstream and downstream sensor cables must now be made. Connect a short wire from the center conductor splice to the inner shield pigtail splice on the upstream sensor cable. Using a multimeter determine the upstream sensor cable at the electronic enclosure end by continuity measurement. Identify the upstream cable for later termination.

Remove the shorting wire and using the cap crimps supplied, crimp the larger caps on each spliced pigtail and the small cap on the center conductor splice as shown in Fig. 2. Repeat this procedure for the second cable.

At this point turn power on at the electronics and verify that an OK signal condition appears on the display.

Turn power "OFF".

Using Splice Strips

1. Remove cover off of strips
2. Totally wrap strips tightly around all of the splice connections.

The finished splices should be coiled inside the junction box. When properly placed, the splices should be clear of the junction box cover area. Proper sealing of the junction box is necessary for watertight integrity.

This completes the triax cable splice connection.

QuickCal Menu Functions

Section

3

Flow **00** GPM
 Vel. **00** FPS
 FwdT **00** GAL
 X1
 Status - Okay

MENU

The screen to the left represents the main screen. However, the user may select the desired lines to be displayed on the main screen. Programming of the main display will be explained later in the manual. To program, recalibrate or change any function in the Vantage 4000, press the “MENU” key. This will display the Main Menu for all of the functions of the Vantage 4000 QuickCal firmware. Below is a quick reference for the main menu and a brief description of each to allow the user to navigate to the required locations.

>01) Review Meter	Selection of this will display the application set up parameters and sensor orientation (V, Z and W shot)) and the sensor separation that the meter is programmed.	
>02) Program	01) Measure Units	To assign engineering units for flow, velocity and measurement.
	02) Sensor Install	To calibrate pipe parameters. (pipe size, pipe material & schedule, fluid, sensor type and mounting style (V, Z and W shot) and Sensor installed cable lengths.
	03) Totalizer	To select totalizer engineering units and multiplier.
	04) 4-20 Outputs	To adjust, assign and set full scale of the 4-20ma output and to assign low flow shutdown.
	05) Damping	To adjust damping time.
	06) Lost Signal	To adjust Lost signal time and Fail to zero or span.
	07) Flow Sim	Flow simulation
	08) Integrator	To assign closure for contact integrator.
	09) Setpoints	To assign setpoints. (e.g. Hi or Lo alarms)
	10) Relays	Relay assignment for all relays.
	11) Meter Factor	Zero Offset Adjustments
>03) Daily Sum	01) Daily Sum	To review daily average, minimum and maximum parameters
>04) Data logger	01) Set Time/date	To set the time and date
	02) Storage Rate	To set logger storage intervals.
	03) Secondary	To set secondary trip point and time intervals.
	04) Log Channels	To set channels to log and values to log.
	05) View Data	To review logged channel history.
	06) Amount Stored	To review time, amount of data stored and amount left.
	07) Clear Data	To clear all stored logger data.
>05) System Setup	01) Language	To set unit to display language to be used.
	02) Display	To set display contrast and backlighting.
	03) Comm. Ports	To set RS-232 & 485 communications and baud rates.
	04) Display Modes	To select display lines to be viewed on main screen.
	05) Options	To select additional relays and Isolated 485.
	06) Totals Reset	To reset the totalizer.
	07) New Password	To change password.
	08) Summary Reset	To clear daily summary.
	09) Sensor Option	To set sensor power from Normal to High or to change polarity of sensors.
	10) Meter reset	To reset to factory defaults.
	11) New Firmware	To upload new firmware into meter.

Main Flow Screen: The main flow screen will have four pages: **Main Flow** screen (to view flow and totals, **Alarms Tripped** screen (to review alarms tripped and relays energized), **Sensor Signal and Gain** screen (to view the transmit and receive signal and the gain strengths) and the **Phase and Reynolds #** screen (internal timing). To view these screens press the UP key.

>01) Review Meter: To review the application parameters and the sensor orientation (vee shot, zee shot, or W shot) that the meter is programmed for press the Menu key and then the 01 key. The first screen will allow the user to review the **sensor separation** that is required for the application and the sensor orientation (V, Z, or W Shot). Press the Enter key and the next screen (**Program Parameters**) will appear.

PIPE MTL	XXXXXXXXXX
WALL THK	****
PIPE OD	****
SENSOR TYP	
*****(FREQ)	
FLOW @ 20 MA	****
LINER MTL	****
LINER THK	****

These are the parameters that the meter has been calibrated to. This will allow the user to use a quick check for pipe size, sensor type and frequency and the maximum flow rate for the 4-20 mADC output. Press the Enter key.

Press the Enter key to return to the main menu.

>02) Program

01) Measure Units:

From the main screen press the **MENU** key, number **02**. Enter Security ID (00000000 from the factory), press **ENTER** key and number **01**.

Flow Units:

Select the flow engineering unit desired by pressing the number in front of the selection. Units available are:

- | | | |
|------------|------------------------------|----------------------------------|
| Flow Units | 01) GPM, gallons/minute | 09) LPD, liters/day |
| 01) GPM | 02) GPD, gallons/day | 10) MLD, million liters/day |
| 02) GPD | 03) MGD, million gallons/day | 11) MS3, cubic meters/second |
| 03) MGD | 04) CFS, cubic foot/second | 12) M3H, cubic meter/hour |
| 04) CFS | 05) CMF, cubic foot/minute | 13) M3D, cubic meter/day |
| 05) CFM | 06) CFD, cubic foot/day | 14) IGM, imperial gallons/minute |
| 06) CFD | 07) LPS, liters/second | 15) BPH, barrels/hour |
| | 08) LPM, liters/minute | |

After pressing the selected flow units number desired the next screen will automatically appear:

Flow Display Format:

The Flow Display Format screen simply asks how many digits you want to show to the right of the decimal point. Press the number that corresponds to your selected value: 01) #, 02) #.#, 03) #.##. Example: GPM, #, will show a direct flow reading (e.g. 100 GPM).

Enter the number in front of the desired Flow Display format and the program will automatically display the Dimension Units screen.

Dimension Units:

The dimension units will allow the user to select the engineering measuring units desired to be selected. Available dimensional units are: 01) Inches, 02) Feet, 03) Meters, 04) Centimeters and 05) Millimeters.

After pressing the selected dimension units number desired the program will automatically take you back to the Program/Cal. Screen.

>02) Program (Continued)

>02) Sensor Install:

The sensor install functions will allow the user to select pipe size, pipe material, fluid parameters and sensor type selections. From the main screen press MENU, 2, press Enter, pass the password screen and press 2. The first screen to appear is for programming the unit for the sensor type to be used.

Sensor Type:

Sensor Type:

01) Strap On

02) Wetted

03) Windowed

- 01) Strap On style sensors. This style of sensor is the sensor that will be associated with outside the pipe mounting.
- 02) Wetted Sensor style is associated with the hotshot style and the internal wetted type sensors.
- 03) Windowed style sensor is associated with the fabricated windowed spool type sensor.

After pressing the number desired the program will automatically take you to the screen for selection of the associated sensor model.

NOTE: The Sensor Model numbers and operating frequencies are designated on the sensor itself. If you do not know the sensor type look on the sensor tag.

Sensor Model:

01) Strap On Sensor:

- 01) V30S-1280 is the small new style strap on sensor and is 1280KHZ operating frequency.
- 02) V30ST-1280 is the small new style strap on sensor for high temperature applications and is 1280KHZ operating frequency.
- 03) V30L-1280 is the large new style strap on sensor and is 1280KHZ operating frequency.
- 04) V30LT-1280 is the large new style strap on sensor for high temperature applications and is 1280KHZ operating frequency.
- 05) V30S-640 is the small new style strap on sensor and is 640KHZ operating frequency.
- 06) V30ST-640 is the small new style strap on sensor for high temperature applications and is 640KHZ operating frequency.
- 07) V30L-640 is the large new style strap on sensor and is 640KHZ operating frequency.
- 08) V30LT-640 is the large new style strap on sensor for high temperature applications and is 640KHZ operating frequency.
- 09) V52S-1280 is the small new style strap on sensor used on thin wall and copper/brass pipe applications and is 1280KHZ operating frequency.
- 10) V52ST-1280 is the small new style high temperature strap on sensor used on thin wall and copper/brass pipe applications and is 1280KHZ operating frequency.
- 11) V52L-1280 is the large new style strap on sensor used on thin wall and copper/brass pipe applications and is 1280KHZ operating frequency.
- 12) V52LT-1280 is the large new style high temperature strap on sensor used on thin wall and copper/brass pipe applications and is 1280KHZ operating frequency.
- 13) SO30-1280 is the old style strap on sensor used with the older Model 4500 and is 1280KHZ operating frequency.
- 14) ST30-1280 is the old style high temperature strap on sensor used with the older Model 4500 and is 1280KHZ operating frequency.
- 15) SO30-640 is the old style strap on sensor used with the older Model 4500 and is 640KHZ operating frequency.
- 16) ST30-640 is the old style high temperature strap on sensor used with the older Model 4500 and is 640KHZ operating frequency.
- 17) SO52-1280 is the old style strap on sensor used with the older Model 4500 on thin wall or copper/brass pipes and is 1280KHZ operating frequency.

>02) Program (Continued)

- 18) ST52-1280 is the old style high temperature strap on sensor used with the older Model 4500 on thin wall or copper/brass pipes and is 1280KHZ operating frequency.

02) Wetted Sensor:

- 01) V20WT1-12 is the new style hotshot wet tap style sensor and is 1280KHZ operating frequency.
- 02) V20WT1-64 is the new style hotshot wet tap style sensor and is 640KHZ operating frequency.
- 03) WFF-2 is the internal wetted sensor for pipe sizes 12" – 36" and is 1280 KHZ operating frequency.
- 04) WFF-2 is the internal wetted sensor for pipe sizes 12" – 36" and is 640 KHZ operating frequency.
- 05) WR-2 is the internal wetted sensor for pipe sizes > 36" and is 1280 KHZ operating frequency.
- 06) WR-2 is the internal wetted sensor for pipe sizes > 36" and is 640 KHZ operating frequency.
- 07) WFG-1 is the wetted 2" flanged sensor and is 1280 KHZ operating frequency.
- 08) WFG-1 is the wetted 2" flanged sensor and is 640 KHZ operating frequency.
- 09) HS3-1280 is the hotshot style sensor and is 1280 KHZ operating frequency.
- 10) HS3-640 is the hotshot style sensor and is 640 KHZ operating frequency.

03) Windowed:

- 01) WD-1-12 is the windowed sensor and is 1280KHZ operating frequency.
- 02) WD-1-64 is the windowed sensor and is 640KHZ operating frequency.

After pressing the selected sensor style number desired, the program will automatically take you to the Pipe Material screen.

Pipe Material
1) Carbon Stl
2) Stainless Stl
3) PVC
4) Cast Iron
5) Ductile Iron
6) Asbestos Cmmt
7) Copper
8) Brass
9) Other

Pipe Material:

The pipe material screen will allow you to select the pipe material for the unit. Selections are:
Carbon Steel, Stainless Steel, PVC, Cast Iron, Ductile Iron, Asbestos Cement, Copper, Brass and Other. If Other is selected you will need to enter the Sonic Velocity of the material.

After pressing the selected pipe material number desired, the program will automatically take you to the Pipe Schedules screen.

Pipe Schedules:

The Pipe Schedules screen will allow the user to select the pipe schedule of the pipe material chosen. If the pipe schedule is not known select "Other" and the program will allow the user to enter the Pipe O.D. and the Wall Thickness for the application.

After pressing the selected pipe schedule number or entering the O.D. and wall thickness desired, the program will automatically take you to the Pipe Size screen.

Pipe Size:

Press the appropriate number in front of the pipe size desired if the O.D. and pipe wall thickness has not already been entered.

After pressing the selected pipe size number desired the program will automatically take you to the Liner Material screen.

Liner Material:

Selections are: 01) None, 02) Epoxy, 03) Glass, 04) Bitumastic, 05) Rubber, 06) Mortar, and 07) Other.

After pressing the selected pipe liner number desired the program will automatically take you to the Liner Thickness screen. If 01) None was selected the next screen will be the Fluid Type screen.

>02) Program (Continued)

Liner Thickness:

If a pipe liner has been selected enter the thickness of the pipe liner in the engineering units designated and press the Enter key. This will automatically take you to the Fluid Type Screen.

Fluid Type:

The Fluid Type screen will allow you to select the fluid type of the media to be measured.

For water, wastewater and sewage select "01) Water". This selection will automatically take you to the Sensor shot type screen.

If the fluid is other than water select "02) Other". When using this screen you will need to enter the following fluid media information:

- Sonic Velocity of fluid in FPS (feet per second)
- Fluid Viscosity in Centipoise (Cp)
- Specific gravity of fluid

If the sonic velocity of the fluid is not known you may call Eastech Badger at 1-800-226-3569. We have a library of various fluids and the associated sonic velocities.

After entering the fluid parameters the next screen will be the Sensor Shot Type screen.

Sensor Shot Type:

The Sensor Shot Type screen will allow the user to program for the sensor placement on the pipe. Selections are:

- 01) Z Shot, sensors are mounted on opposite sides of pipe
- 02) V Shot, sensors are mounted on the same side of pipe
- 03) W Shot, sensors are mounted on the same side of pipe (usually 1" – 3" pipe sizes).

Sensor Cable Length:

There will be two screens to enter sensor cable length. The first screen will be for Sensor #1 and the second screen will be for Sensor #2. Simply type in the cable length used for each sensor.

This completes the 02) Sensor Install selection. To review the sensor separation go to Review Meter.

>03 Totalizer

Totalizer Units:

- 01) GAL
- 02) MET3
- 03) LTRS
- 04) IGAL
- 05) BARR
- 06) CUFT
- 07) ACFT

Totalizer Units:

Select the Totalizer Units desired by pressing the number designation in front of the selection. Available totalizer units are:

GAL (gallons) MET3 (cubic meters) LTRS (liters)
IGAL (imperial gallons) BARR (barrels) CUFT (cubic feet)
ACFG (acre feet)

After pressing the selected totalizer engineering units desired the displayed totalizer multiplier screen will appear.

Totalizer Multiplier:

The Totalizer Multiplier screen will allow the user to select the multiplier for the totalizer that is to be displayed on the main screen. The multiplier choices are:

- 01) x .01 05) x 100
- 02) x .02 06) x 1000
- 03) x 1 07) x 10k
- 04) x 10

>02) Program (Continued)

>04) 4-20 Outputs:

This section will allow the user to:

- 01) Adjust Fwd (adjust forward flow)
- 02) Adjust Rev (adjust reverse flow)
- 03) Fullscale (assign maximum flow and low flow shutdown)

4-20 Output Assignment and Adjustment

04) 4-20 Out	Selection 4 in the programming menu is the 4-20mA output and assignment adjustment. Press the 4 key to adjust or assign the 4-20mADC output.
--------------	--

4-20 Loop Output 01) Adjust Fwd 02) Adjust Rev 03) Fullscale	1) Adjustment: To adjust or calibrate the 4-20mADC for the forward flow output press the 01 key. To adjust or calibrate the 4-20 mADC for the reverse flow press 02 (Model 2600 only). To program the full scale of the 4-20 mADC output press 03.
---	--

>1) Up 2) Down >3) Coarse 4) Fine >5) 4 mA 6) 20 mA	To adjust Zero: Press the 5 key, the cursor arrow will appear before the 5) 4 mA line. Press the 3 key for coarse adjustment or the 4 key for fine adjustment. Now press the 1 key to adjust the mA upwards or the 2 key to adjust downwards.
--	---

To adjust Span: Press the 6 key, the cursor arrow will appear before the 6) 20 mA line. Press the 3 key for coarse adjustment or the 4 key for fine adjustment. Now press the 1 key to adjust the mA. upwards or the 2 key to adjust downwards.

To assign the 4-20mA loop press the 02) Assignment key.

Application Fullscale Flowrate xxxx.x GPM	To assign the 20mADC full scale value press 03) Fullscale. The following screen will appear: Type in the desired full scale flow rate that is desired for the 20mADC. Press the Enter key. The next screen is the Application Flow Rate Shutdown screen. This screen will allow the user to select a low flow shutoff for the display and the 4-20mADC output. Type in the low flow shutdown in the flow engineering units displayed. Press the enter key to return to the main menu.
--	--

>05) Damping:

>05) Damping	This option will allow the user to select the damping or response time of the flow meter. Press the 05 on the keypad.
--------------	---

>02) Program (Continued)

Output Damping Adjustment

To adjust the 4-20mA output damping press the 7 key. This will allow the user to adjust the damping time. The damping times available are:

- 01) None
- 02) 10 Seconds
- 03) 30 Seconds
- 04) 60 Seconds
- 05) 120 Seconds

Enter the number in front of the desired damping time.

>06) Lost Signal:

Lost Signal Setting

To adjust the Lost Signal Time. (This is how long the meter will hold the last value after losing the signal until failing to the Lost Signal 4-20 mADC assignment).

06) Lost Signal

To set the Lost Signal time press the 06) key. The lost signal times available are:

- 01) 5 Seconds
- 02) 15 Seconds
- 03) 30 Seconds
- 04) 60 Seconds
- 05) 2 Minutes
- 06) 4 Minutes
- 07) 8 Minutes
- 08) 16 Minutes

After pressing the desired number, or ENTER key, the next screen to appear is the Lost Signal Action assignment. In this screen the user will select the default for the 4-20mADC output during a lost signal condition. The selections are:

- 01) Fail to Zero
- 02) Fail to Span
- 03) Hold last value

Press the number desired, this will return to the main program screen.

>07) Flow Simulation:

>07) Flow Sim.

Flow Simulation

The flow simulation screen will allow the user to check the user to simulate flow. Press the MENU key to return to the main program screen.

>08) Integrator:

>08) Integrator

Integrator Setup

The next option in the program menu is the Integrator screen. To select this, press the 08. This screen will allow the user to assign the contact closure time for a contact integrator. The cursor will appear on the most significant digit. Use the number keys to enter the totalized flow value you want to have for a contact output. Press the

ENTER key to return to the main program screen.

>02) Program (Continued)

>09) Setpoints:

>09) Setpoints

Programming Setpoints

This selection will allow the user to assign up to two setpoints for High or Low alarm conditions. Press the 09 key to enter the setpoint selections. Press the 01) key for Setpoint #1. Press the 02) key for Setpoint #2. The next screen allows the user to assign the setpoint selected to velocity or flow. Press the 01) key for Velocity and the 02) key for Flow. The velocity selection will be in the engineering units selected for velocity. The flow selection will be in engineering units selected for flow. The next screen will allow the user to input ON and OFF points for the setpoint selected. For Low alarm the ON value will be less than the OFF value. For High alarm the ON value will be greater than the OFF value. To program move the cursor to the left most significant digit by using the DOWN/LEFT arrow key. Enter the number desired by using the keypad. The cursor will advance to the right after the selection is entered. Press the ENTER key. The Setpoints must be assigned to a Relay.

>10) Relays:

>10) Relays

Relay Assignment

The next option in the program menu is the Relays screen. To select this press 10) on the keypad. This option will allow the user to assign each of the three relays to the following selections:

01) None	04) Setpoint #3	07) Reverse Flow	10) Cont In
02) Setpoint #1	05) Lost Signal	08) Fwd Total	
03) Setpoint #2	06) 4-20 Loop	09) Rev Total	

Press the number in front of the selection desired on the keypad.

>11) Meter Factor: The meter factor screen will allow the user to either manually, or automatically set zero offset.

- 01) Manual zero. To set zero offsets while fluid is flowing.
- 02) Auto zero. To set zero offset while at zero flow.

This concludes >02) Program menu functions.

>03) Daily Sum

This function will allow the user to review the daily Sum of the Logger. To access the Daily Sum screen, press the 03) key on the keypad.

Daily Sum: View the Average, Minimum and Maximum flows and the time of the event for the last eight days of flow.

Press the ENTER key to return to the main program menu.

This concludes the Daily Sum selections.

>04) Data Logger

>04) Data Logger

The next selection in the program menu is the data logger selection. There are five selections in the data logger menu.

01) Set Time/Date: Press the UP key to move the arrow to the date or time that is to be changed. Press the number value on the key pad to change. Note the time is entered and viewed as military time.

02) Storage Rate: This will allow the user to select the storage rate for the logging. Selections are:

- | | | |
|--------------|---------------|---------------|
| 01) 1 minute | 03) 10 minute | 05) 30 minute |
| 02) 5 minute | 04) 15 minute | 06) 60 minute |

03) Secondary: This will allow the user to select a secondary log rate to store logging at a different interval than the main interval. This may be used to store at faster intervals during storms or flow events. The selections available are:

- | | | | |
|---------------|----------------|----------------|----------------|
| 01)Not active | 02)Setpoint #1 | 03)Setpoint #2 | 04)Setpoint #3 |
|---------------|----------------|----------------|----------------|

If set points are selected then the next screen will be storage rate times available.

04) Log Channels: There are up to 8 channels available for logging. The selections for each channel are:

- | | | | |
|----------------|-------------|-----------------|-----------------|
| 01) Not Used | 04) Flow 1 | 07) Total 2 | 10) Flow1+Flow2 |
| 02) Velocity 1 | 05) Flow 2 | 08) Alarms | 11)Vel1-Vel2 |
| 03) Velocity 2 | 06) Total 1 | 09) Flow1-Flow2 | |

05) View Data: View logged data in graphic form for each of the eight channels available to log. Select the channel to be viewed by pressing the number on the keypad. Press the UP or DOWN key to scroll through the data.

06) Amount Stored: View the logger time and time to store, amount of logging stored and the amount of free space to store.

07) Clear Data: Press the 5 key to clear all stored data.

This completes the Data Logger selections.

>05) System Setup

>05) System Setup

The system setup option will allow the user to set up the Vantage 4000 for the following options:

>05) System Setup (Continued)

01) Language: This will allow the user to select the language displayed in the Vantage 4000. The options are: 01) English, 02) German, 03) Spanish.

02) Display: Choosing this feature allows the user to select the contrast of the display from 01) Highest to 08) Lowest. This feature also allows to display the back light, to turn it off or to program for a timed “off” of the display if the key pad is not touched in a selected time interval.

03) Communications: This option will allow the user to set the baud rate, flow control and slave I.Ds of the RS-232 and RS-485 communications. The Comm. Objects is not utilized.

04) Display Modes: This option will allow the user to select the four display lines to be viewed on the main screen during operation. The options for the display lines are:

Model 4600:

- 01) Display Mode 1: Flow, Forward and Reverse Totalizer and Status
- 02) Display Mode 2: N/A
- 03) Display Mode 3: N/A
- 04) Display Mode 4: N/A

Model 4400:

- 01) Display Mode 1: Flow, Velocity, Totalizer and Status
- 02) Display Mode 2: N/A
- 03) Display Mode 3: N/A
- 04) Display Mode 4: N/A

05) Options: N/A

06) Totals Reset: This option will reset the totalizer to zero. Press 5 to begin.

07) New Password: This option will allow the user to change the password to enter into the QuikCal programming.

08) Summary Reset: This clears the Daily Summary memory.

09) Sensor Option: 01) Sensor Power. This screen will allow the user to use Normal or a High transmit power. Most strap on sensors will use high power and the windowed spool sensor will use low power.

02) Sensor Polarity: This screen will allow the user to change the polarity of the sensors. If the wiring of the upstream and downstream sensor have been inadvertently reverse during installation choose the Reversed sensor polarity in this screen instead of rewiring the sensors.

10) Meter Reset: This option will reset all parameters to the factory defaults.

11) New firmware: This option will allow the user to upload any new firmware to the latest revision.

This completes the System Setup function menus in the 4000 structure.

WARRANTY

Eastech Badger warrants meters and parts manufactured by it and supplied hereunder to be free from defects in materials and workmanship for a period of 3 years from date of shipment. If within such period any meters or parts shall be proved to Seller's satisfaction to be defective, such meters or parts shall be repaired or replaced at Seller's option. Seller's obligation hereunder shall be limited to such repair and replacement and shall be conditioned upon Seller's receiving written notice of any alleged defect within 10 days after its discovery and, at Seller's option, return of such meters or parts f.o.b. to Seller's factory. THE FOREGOING WARRANTY IS EXCLUSIVE AND IN LIEU OF ALL OTHER EXPRESS OR IMPLIED WARRANTIES WHATSOEVER INCLUDING BUT NOT LIMITED TO IMPLIED WARRANTIES (EXCEPT OF TITLE) OF MERCHANTABILITY AND FITNESS FOR A PARTICULAR PURPOSE. Eastech Badger shall not be liable for any defects attributable to acts or omissions of others after shipment, nor any consequential, incidental or contingent damage whatsoever.

A claim for equipment damaged in transit is the sole responsibility of the customer.

NUCLEAR DISCLAIMER

Equipment sold by Eastech Badger is not intended for use in connection with any nuclear facility or activity unless covered by a specific quotation where the conditions of such usage will be detailed. If equipment is used in a nuclear facility or activity without a supporting quotation, Eastech Badger disclaims all liability for any damage, injury or contamination, and the buyer shall indemnify and hold Eastech Badger, its officers, agents, employees, successors, assigns and customers, whether direct or indirect, harmless from and against any and all losses, damages or expenses of whatever form or nature (including attorney's fees and other costs of defending any action) which they, or any of them, may sustain or incur, whether as a result of breach of contract, warranty, tort (including negligence), strict liability or other theories of law, by reason of such use.

All rights reserved. All data subject to change without notice.
