

SCOPE OF MANUAL

This manual contains information concerning the installation, operation and maintenance of the Model 3050 Recorder. To ensure proper performance of the meter, the instructions given in this manual should be thoroughly understood and followed.

Keep the manual in a readily accessible location for future reference.

Changes and additions to the original edition of this manual will be covered by a "CHANGE NOTICE" supplied with the manual. The change notice will explain any changes made to the product described in this manual.

MODEL 3050 TABLE OF CONTENTS

	Page		Page
		OPERATION	
Unpacking and Inspection.....	1	General Description.....	7
General Specifications	2	Status Mode.....	8
		Calibration Mode.....	9
INSTALLATION PROCEDURE		Error Screens.....	16
Electronics		Hexadecimal Conversions.....	17
Enclosure Mounting.....	3	Illustrated Parts List	19
Wiring Connections	5	Troubleshooting Diagram	21



To avoid damage in transit, Badger products are shipped to the customer in special shipping containers. Upon receipt of the product, perform the following unpacking and inspection procedures:

NOTE: If damage to the shipping container is evident upon receipt, request the carrier to be present when the product is unpacked.

a. Carefully open the shipping container following any instructions that may be marked on the box. Remove all cushioning material surrounding the product and carefully lift the product from the container.

Retain the container and all packing material for possible use in reshipment or storage.

b. Visually inspect the product and applicable accessories for any physical damage such as scratches, loose or broken parts, or any other sign of damage that may have occurred during shipment.

NOTE: If damage is found, request an inspection by the carrier's agent within 48 hours of delivery and file a claim with the carrier. A claim for equipment damage in transit is the sole responsibility of the customer.

GENERAL SPECIFICATIONS

INPUTS	3 Selectable Analog Channels: 0-20 mADC, 4-20 mADC or 1-5 VDC single input or summation. Pulse: 0-150 ppm to 0-1000 pps, field adjustable.		
OUTPUTS	4-20 mADC signal into max. 800 ohms 2 dry contact SPDT relays assignable to any of the following: High or low alarms, contact integrator, loss of input signal, EEPROM failure. Rated for 0.25 amp @ 120 VAC or 0.5 amp @ 24 VDC.		
DISPLAY	2 line, 24 alphanumeric character per line Liquid Crystal Display. Displays instantaneous flow rate (or pressure, or temperature), totalization, alarm indication and is used to program the recorder through menu driven prompts.		
RECORDING	12 inch circular chart with 24 hour, 7 day or 31 day selectable chart speed, single disposable red ink pen.		
PROGRAMMING	Menu driven display prompt with 5 key tactile feedback keypad.		
ENCLOSURE	Indoor: NEMA 12, metallic; Outdoor: NEMA 4X, non-metallic.		
TEMPERATURE LIMITS	Indoor: 32° F to 150° F (0° C to 65° C) Outdoor: -40° F to 150° F (-40° C to 65° C)		
POWER REQUIREMENTS	Standard: 117 VAC, 50/60 Hz +/- 10% Optional: 230 VAC, 50/60 Hz +/- 10%		
PERFORMANCE	Recording	Indicating	Totalization
	Accuracy: +/- 0.5% of span	+/- 1% or 1 LSD	+/- 0.25%
	Linearity: +/- 0.5% of span	+/- 0.5%	
	Hysteresis: +/- 0.5% of span		
	Repeatability: +/- 0.5% of span		

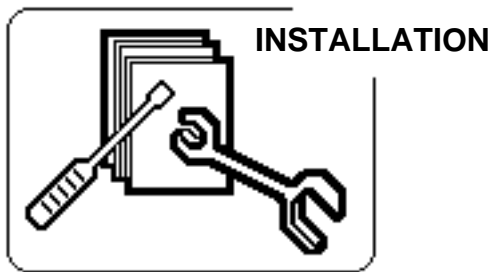

ENCLOSURE DESCRIPTION

The Model 3050 Recorder is housed in either a NEMA 12 or NEMA 4X enclosure and is capable of accommodating the input signal from 1, 2 or 3 DP Cells and provide a single output for indicating, totalizing and recording flow or level.

The NEMA 12 enclosure is suitable for indoor use and designed to be panel mounted. It can be supplied with heater and thermostat for indoor installations in buildings that are not heated in the winter. Mounting hardware is provided for panel mounting of the enclosure. Care should be taken when selecting the mounting location so that the recorder door can be opened completely for access when changing charts.

INDOOR ENCLOSURE DIMENSIONS

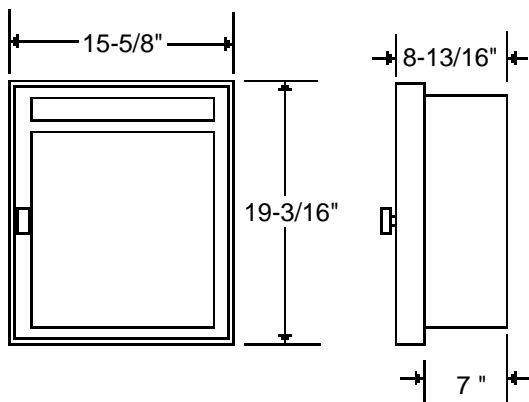

The NEMA 4X enclosure is suitable for outdoor use and can be wall or pole mounted. It comes equipped with heater and thermostat. The door can be supplied with or without a window. The door is provided with two lockable latches. Caution should be used when mounting the enclosure so that it is not exposed to direct sunlight. **A sun shield is recommended to prevent the temperature inside the enclosure reaching above the maximum rating of the electronics** (see temperature specification under General Specifications). Viewing window is optional.

OUTDOOR ENCLOSURE DIMENSIONS

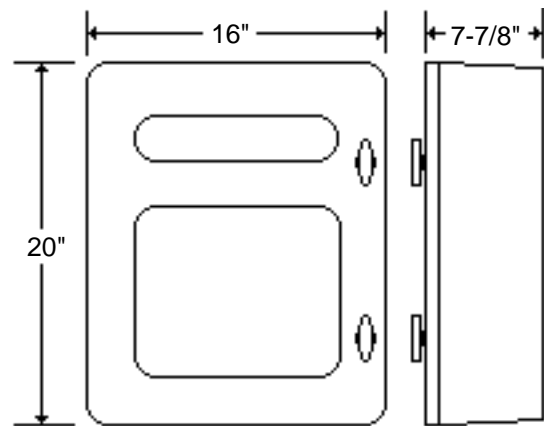

INDOOR PANEL MOUNTING

Prior to mounting the enclosure, it is recommended that the knockouts for the conduit fittings be removed. This should be done with the enclosure resting on a solid surface.

A hole 17-7/8" high by 14-1/4" wide is required for inserting the enclosure in a panel. Slide the recorder into the panel. Install the four mounting brackets into the slots in the sides of the enclosure as shown below. Tighten the mounting screws until the enclosure is secure to the panel.

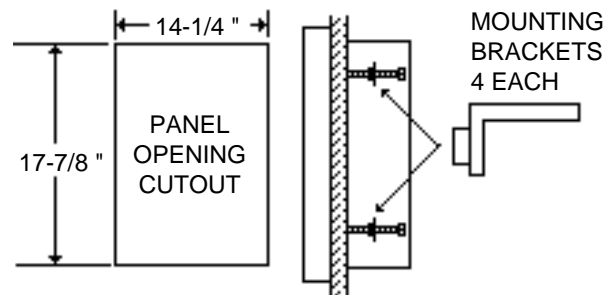

OUTDOOR ENCLOSURE MOUNTING

The NEMA 4X outdoor enclosure is provided with four mounting feet which are to be installed by the user at the orientation desired. Pictured below is the installation detail of the feet and the mounting hole dimensions.

If the outdoor enclosure has the window option, **do not mount facing the sun or install a sun shade to prevent overheating of the electronics inside the enclosure.** See below for DP cell wiring connections.

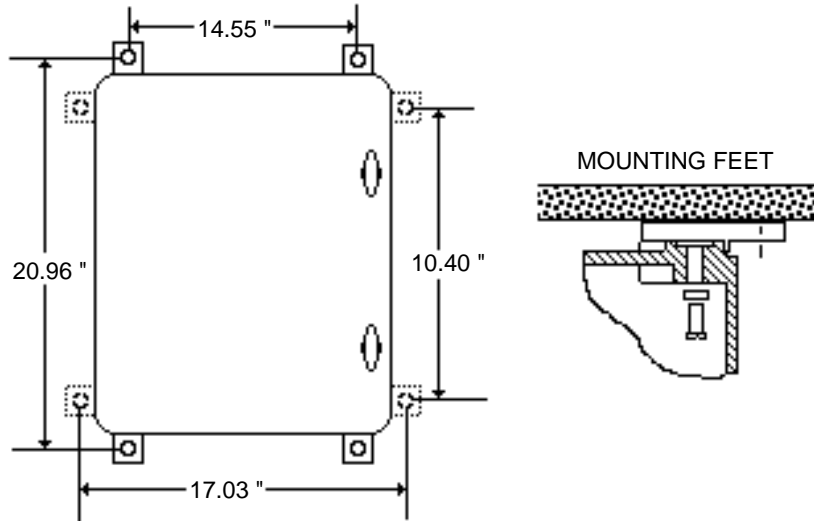

WIRING CONNECTIONS

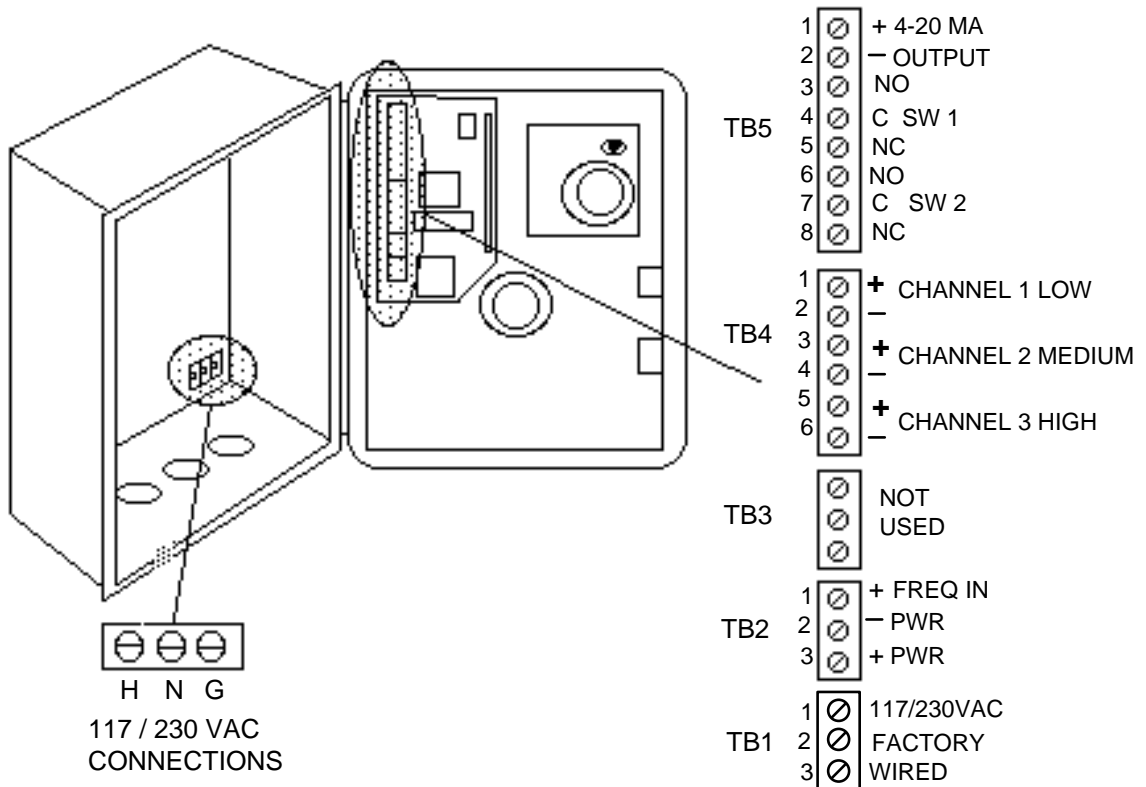

The indoor case has six 7/8" diameter knockouts for use of 3/4" conduit connections. Three are located on the bottom of the case and three on the back of the case. The three you use will depend on whether you panel or wall mount the enclosure.

To reduce the chance of noise on the signal input wires, the input wires should be routed in separate conduit from the power wiring.

Local regulations for proper grounding and connection of the power to the recorder should be strictly followed.

The power wires are connected to the terminals located on the inside back of the recorder. The AC voltage which the recorder has been setup will be clearly marked near the terminal strip. **Verify that you are connecting the proper voltage to the recorder.** The terminal labeled H is the High (black) wire, the terminal labeled N is the Neutral (white) wire and the terminal labeled G is the Ground (green) wire. The power wires from the terminal strip to the circuit board are prewired at the factory.

MULTIPLE DP CELL INPUTS

The following channels are available for up to three DP Cell inputs.

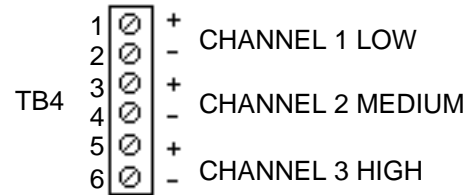

The above wiring diagram shows the wiring connections for current or voltage input signals from the DP cells. The Data Sheet furnished in the front of this manual will indicate recorder setup. If this is different from the output of your DP cell, contact the factory for corrective action.

The terminal blocks on the circuit board have snap on connectors. To connect the input and output wires, pull off the connectors from the terminal strips. Route the signal wires through the flexible wiring raceway between the back case and front door. Loosen the screws on the connectors. Strip off about 1/4 inch of insulation from the wires. Insert the wire into the proper connector and tighten the screw securely. After connecting all of the wires to the connector, snap the connector back on the terminal strip.

4-20 mA RETRANSMIT OUTPUT

4-20 mADC OUTPUT

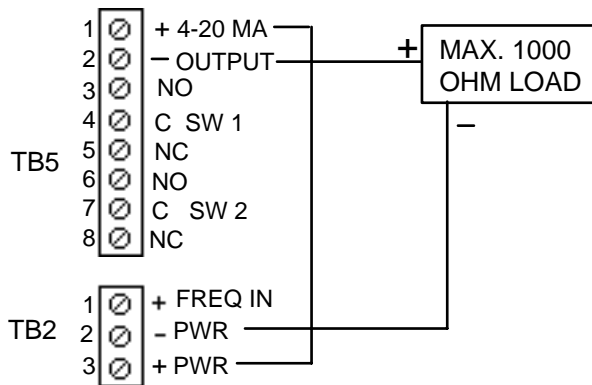

The two-wire 4-20 mADC will be a characterized output. For example, if the 4-20 input is from a DP Cell and the 3000+ recorder is setup to extract the square root from the raw signal, the 4-20 output will be linear to flow not differential. DC power must be connected in series with the load, as shown above.

RELAY OUTPUTS

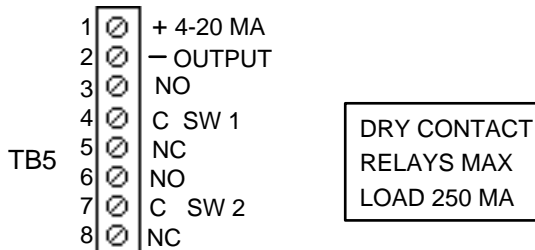

Relays are assignable to different functions. See Operating Section of the Manual.

INSTALLATION OF CHART AND PEN ALIGNMENT

Open the recorder door and unscrew the knob from the chart hub. Lift the pen arm with the pen lifter off the chart plate. Remove the protective cap from the fiber tipped pen. Lower the pen close to the chart plate and adjust the pen until it aligns with the reference scribe on the chart plate.

Lift the pen back up with the pen lifter. Place a chart on the chart hut and screw the knob onto the hub loosely. Slide the edge of the chart under the five plastic holders. Rotate the chart until the proper time line is aligned with the pen. Tighten the knob to the hub assembly. Remove the backlash by turning the chart knob counterclockwise. Lower the pen arm until the pen is touching the chart.

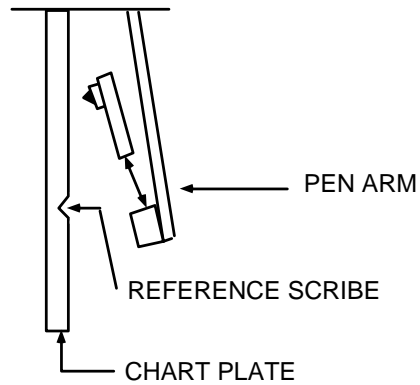

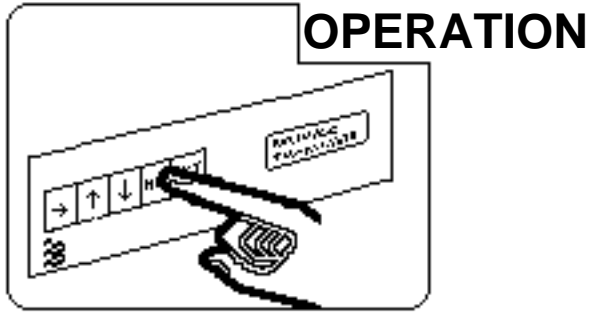

GENERAL DESCRIPTION

The Model 3050 Recorder is a circular chart recorder with microprocessor-based electronics. The unit is designed to accommodate the input from up to three (3) "stacked" DP cells, providing a single output of flow. The unit is supplied with a LCD display for indicating rate and totalization. The rate is displayed with 4 digits and its multiplier and unit of measurement. The totalizer is displayed with 8 digits and its multiplier and unit of measurement.

The display is also used to program the recorder through menu driven prompts. The programming is activated via front panel keys. These keys also activate a Status Mode which will indicate if there are any alarms tripped and perform a self-test operation of the recorder.

The following will describe in detail the various functions of the Model 3050 Recorder and programming steps to recalibrate the recorder in the field if necessary.

INITIAL POWER UP

After installation and wiring of the Model 3050 Recorder, power may be turned on by the power switch on the lower right hand corner of the chart plate.

When power is applied, the display screen will have a solid line across the top of the display for a few seconds. Then the following screen will appear:

3050 RECORDER
BADGER METER INC

This screen informs the user of the Model of the recorder. This screen will be displayed for a few seconds.

The next screen to be displayed is the following:

SOFTWARE REVISION X.XX
SERIAL NUMBER 12345678

This screen identifies the software revision the recorder is operating with and the serial number of the unit. This screen will be displayed for a few seconds.

The next screen shown is the screen that will be displayed during normal operation of the recorder.

*FLOW 1234 X 10,000 GPM
12345678 X 100,000 GAL

The top line displays the flow rate with its multiplier and the unit of measurement. The second line displays the totalized flow (8 digits) with its multiplier and unit of measurement.

The asterisk that is to the left of FLOW may or may not be present. If it is present, it indicates that an alarm has been tripped. The various alarms will be discussed in the Status Mode Section of this manual.

The recorder should be fully operational if there is an input signal from a transmitter. The recorder is programmed at the factory with the information supplied by the user and the Zero and Span have been calibrated.

If the flashing asterisk is present proceed to the Status Mode Section to determine the cause and proper action.

If the user desires to reset the Zero and Span or change any of the parameters of the recorder, proceed to the Calibration Section of this manual.

STATUS MODE

The Status Mode contains the Alarms Tripped screen and the Self Test screen. To enter into the Status Mode press the MENU key and the following screen will appear:

PRESS UP FOR CALIBRATION
PRESS DOWN FOR STATUS

Pressing the DOWN arrow key will allow entry into the Status Mode screens. If you decide not to enter the Status Mode, press the MENU key and you will return to the normal operation screen.

Press the DOWN arrow key and the following screen appears:

- ALARMS TRIPPED -
IN LO HI CHT INT EE

The Alarms Tripped screen will display any conditions that have occurred.

To clear the alarms press the DOWN arrow key. Should an alarm still be tripped, it will still be shown on the display.

The definition of the alarms are as follows:

IN = There is no 4-20 mA signal or the input current is below the pen arm zero current value.

LO = This indicates that the low alarm set point has been tripped. This set point may be changed, refer to the Calibration Section of this manual.

HI = This indicates that the high alarm set point has been tripped. This set point may be changed, refer to the Calibration Section of this manual.

CHT = This indicates that the chart has made a complete rotation and the chart needs to be changed.

INT = Indicates a contact integrator pulse output has occurred.

EE = EEPROM read/write error which indicates a failure in the microprocessor. Consult the factory.

To return to the normal operating screen press the MENU key.

To enter the Self Test screen press the ENTER key and the following screen will appear:

- SELF TEST -
PRESS UP TO ACTIVATE

If you decide not to enter into the Self Test section, press the MENU key and you will return to the normal display screen.

To enter into the Self Test section press the UP arrow key and the following screen will appear:

- SELF TEST -
EEPROM TEST=> PASSED

This tests the EEPROM and indicates if it passed or failed. This takes a few seconds and then the following screen will appear:

- SELF TEST -
VREF TEST=> PASSED

This tests the reference voltage and indicates if it passed or failed. The following screen will appear:

- SELF TEST -
SERVO TEST=> PASSED

This tests the servo drive system and indicates if it passed or failed.

Should any of the screens indicate a failure, contact the factory for the appropriate action to be taken.

Upon completion of the Self Test the unit will return to the normal operating display screen. This completes the Status Mode Section.

3050+MDP CALIBRATION DISPLAY FLOW CHART

TO DO BUTTONS:     

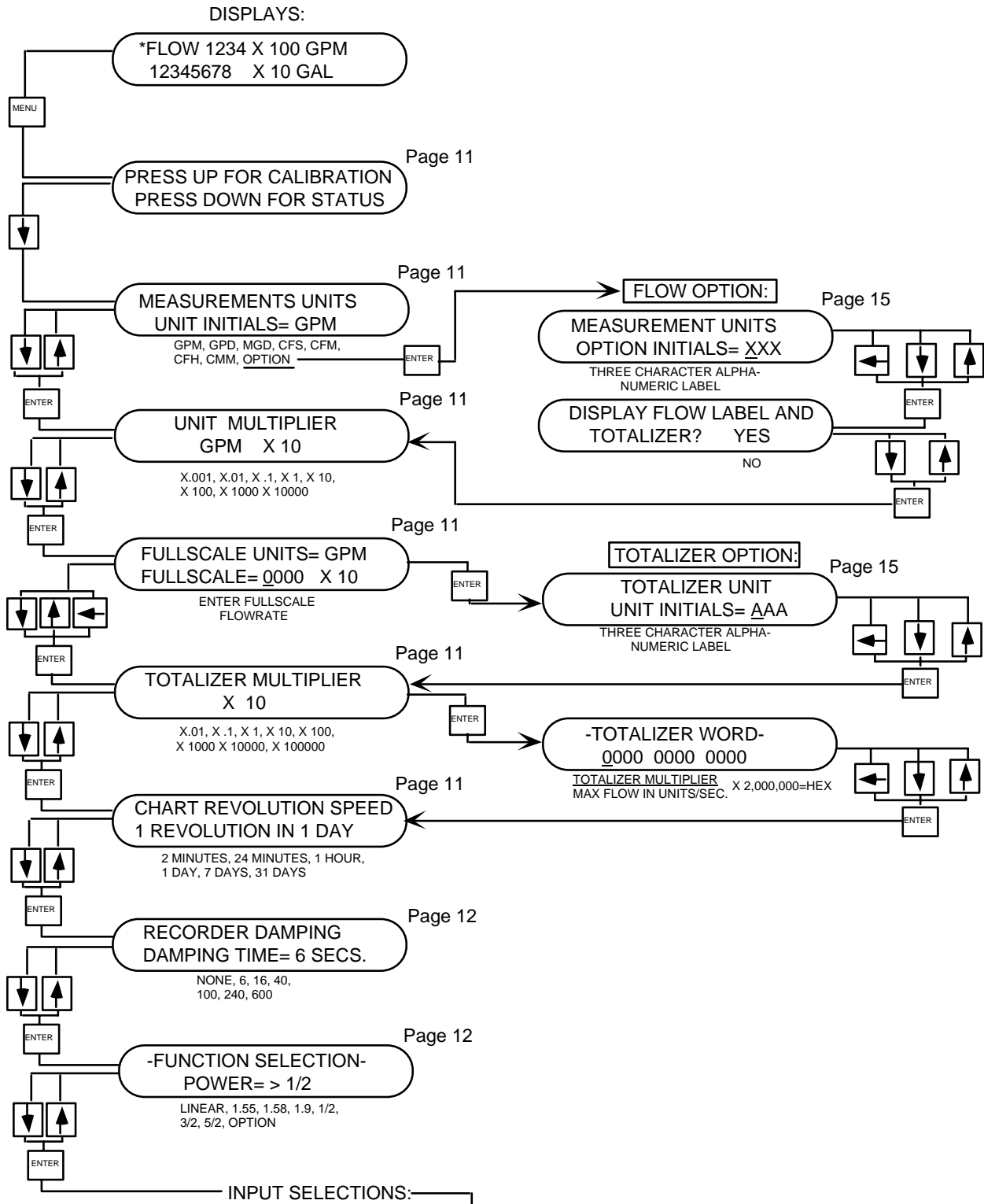

FLOW CHART CONTINUED

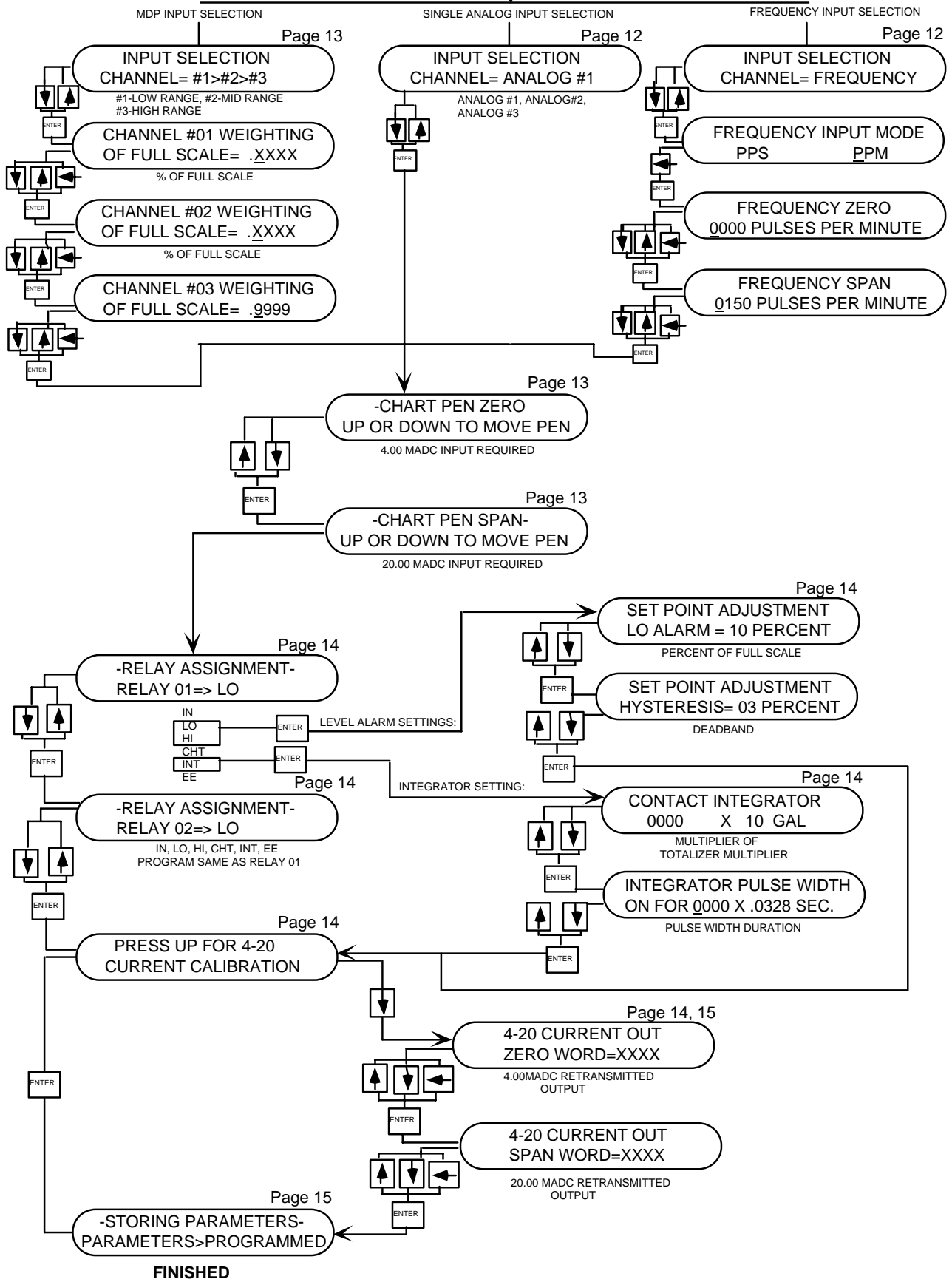

CALIBRATION MODE

The Calibration Mode allows the user to reprogram the 3050 Recorder to different parameters, calibrate the Zero and Span and assign and set the relay outputs.

To enter the Calibration Mode, press the MENU key and the following display screen will appear:

PRESS UP FOR CALIBRATION
PRESS DOWN FOR STATUS

If you decide not to enter the Calibration Mode, press the MENU key and the display will return to the normal operating screen.

When in the Calibration Mode and the desired change has been made and no other changes are desired, you may skip to the end of the calibration screens by pressing the MENU key.

To enter the Calibration Mode, press the UP arrow key and the following screen will appear:

MEASUREMENTS UNITS
UNIT INITIALS=GPM

This screen allows the user to select the engineering unit of measure for the flow rate. To change the units, press the UP or DOWN arrow keys until the desired unit is shown. The engineering units available are:

GPM = Gallons per Minute
GPD = Gallons per Day
MGD = Million Gallons per Day
CFS = Cubic Feet per Second
CFM = Cubic Feet per Minute
CFH = Cubic Feet per Hour
CMM = cubic Meters per Minute
OPTION = Any three letter label can be entered

After you have selected the unit desired, press the ENTER key. If you have selected OPTION, skip to the section entitled OPTION on Page 15.

The next screen, after selecting a standard measurement, allows the selection of the multiplier for the unit of measurement and will appear as follows:

UNIT MULTIPLIER
GPM X 1,000

Press the UP or DOWN arrow key to select the desired flow multiplier. The following multipliers are available:

X.001
X.01
X.1
X1
X10
X100
X1,000
X10,000

Press the ENTER key to store the multiplier. The following screen will appear:

FULLSCALE UNITS=GPM
FULLSCALE = 0000 X 1,000

This screen allows the setting of the full scale range. Press the UP or DOWN arrow keys to change each digit to the desired value and the RIGHT arrow key to move the cursor under each digit. Press the ENTER key and the following screen will appear:

TOTALIZER MULTIPLIER
X 1,000

This screen allows the selection of the totalizer multiplier. Press the UP or DOWN arrow keys to select the desired multiplier and then the ENTER key. The following multipliers are available:

X.01	X100
X.1	X1000
X1	X10,000
X10	X100,000

The following screen will appear:

CHART REVOLUTION SPEED
1 REVOLUTION IN 1 DAY

This screen allows the selection of the chart rotation speed. The following speeds are available:

1 REVOLUTION IN 2 MINUTES
1 REVOLUTION IN 24 MINUTES
1 REVOLUTION IN 1 HOUR
1 REVOLUTION IN 1 DAY
1 REVOLUTION IN 7 DAYS
1 REVOLUTION IN 31 DAYS

- - -

The two dash line positions are for future chart revolution speeds.

Press the UP or DOWN arrow keys to select the desired chart speed and press the ENTER key. The following screen will appear:

RECORDER DAMPING
DAMPING TIME= 6 SECS.

This screen allows the selection of the amount of damping in the response of the pen movement. The damping times available are:

NONE	6
16	40
100	240
600	

These times are in seconds. Press the UP or DOWN arrow keys to select the desired value and then the ENTER key. The following screen will appear:

- FUNCTION SELECTION -
POWER=> LINEAR

POWER=>LINEAR
POWER=>1.55
POWER=>1.58
POWER=>1.9
POWER=>1/2
POWER=>3/2
POWER=>5/2
POWER=>OPTION

The LINEAR function is used where the transmitter output is proportional to flow or the square root function is accomplished in the DP cell.

The 1.55 power is used with 1", 2", 3", 24" Parshall flumes and all Lagco flumes.

The 1.58 power is used with a 6" Parshall flume.

The 1.9 power is used with the Badger Meter Manhole flumes.

The 1/2 power is used with differential pressure transmitters where the output does not have the square root extracted.

The 3/2 power is used with Suppressed Rectangular weirs and Cipoletti weirs.

The 5/2 power is used with all V-Notch weirs.

The OPTION power allows a 16 point HQ curve to be programmed into the recorder. Consult the factory for programming details.

Press the UP or DOWN arrow keys to select the desired function and then the ENTER key. The following screen will appear:

INPUT SELECTION
CHANNEL=ANALOG #1

This screen allows the selection of the desired input channels to be used as the input to the recorder. There are four channels available to connect the input(s) signal(s): ANALOG #1, ANALOG #2, ANALOG #3, AND FREQUENCY.

The ANALOG channels can accept 0-20 mA, 4-20 mA, or 1-5 VDC. The recorder must be setup at the factory for either a current or a voltage input. These channels can be selected individually or summed in any combination.

The frequency channel is used for pulsed inputs. The operating range is 0-1000 pps to 0-150 ppm. Press the UP or DOWN arrow keys to select the desired input channel and then the ENTER key.

The following describes the programming screen sequence if the selection is: ANALOG 1, 2 or 3; FREQUENCY; or SUMMATION.

ANALOG INPUT 1, 2 OR 3 IS SELECTED

Go to Page 13 Chart Pen Zero and Span

FREQUENCY INPUT IS SELECTED

Should this screen be activated, the Multiple DP cell function cannot be operated. After selecting the frequency input channel with the UP or DOWN arrow keys and press the ENTER key, the following screen will appear:

FREQUENCY INPUT MODE
PPS PPM

This screen selects the frequency rate of Pulses Per Minute or Pulses Per Second. Press the RIGHT arrow key to move the cursor under the desired frequency rate and then depress the ENTER key. The following screen will appear:

FREQUENCY ZERO
0000 PULSES PER SECOND

This screen allows the setting of frequency which represents zero. Press the UP or DOWN arrow keys to change the value of each digit and the RIGHT arrow key to move the cursor under the digit to be changed. Press the ENTER key to store this value. The following screen will appear:

FREQUENCY SPAN
0000 PULSES PER SECOND

This screen allows the setting of the frequency which represents zero. Press the UP or DOWN arrow keys to change the value of each digit and the RIGHT arrow key to move the cursor under the digit to be changed. Press the ENTER key to store this value. **Go to Page 13 Chart Pen Zero and Span.**

MULTIPLE DP CELL INPUT SELECTION

The 3050 is capable of accommodating one (1), two (2), or three (3) analog inputs from DP cells. In other words, "stacking" DP cells for extending the range for a differential pressure producer. The 3050 Recorder must be installed per the following sequence or improper operation will occur. Channel 1 must be dedicated to the lowest range DP cell. If only two (2) DP cells are used, the channel selection for the third input should not be activated. For two inputs the selection is as follows:

INPUT SELECTION
CHANNEL 1 = #1 > #2

If three (3) inputs are selected, the combination has to be:

- #1 - Low Range
- #2 - Mid Range
- #3 - High Range

In the input Selection screen there is the following channel combinations that can be selected: Channel = #1>#2, or Channel = #1>#2>#3. Use the UP and DOWN arrow keys to select the channels to be summed and press the ENTER key. This selects input channels for active inputs to the system.

The switching function between each DP cell is accomplished through the lower range cell. For example, in a three (3) cell input as the input reaches a predetermined percentage in the low range cell it switches to the mid range cell. As the input increases the active input switches to the high range cell.

The next two following screens will set the percentage angle of each cell as a function of either differential in inches or flow. Remember: The inputs from the dP cells will be used for channel weighting.

CHANNEL #1 WEIGHTING
OF FULL SCALE=.XXXX

This screen sets the low range value by inputting the full scale flow or (differential in inches) number as a percentage of the full scale value of cell #2. For example, if the high range cell is 0-200 GPM (200"), and the low range cell is 0-20 GPM (20"), then the ratio of the full scale flow or (differential in inches) value of each dP cell is:

$$20/200 = .1$$

Use the UP or DOWN arrow keys to adjust the percent value. Press the ENTER key to store this value. After the ENTER key has been pressed, the following screen will appear:

CHANNEL #2 WEIGHTING
OFF FULL SCALE = .XXXX

This channel must be set to read .9999 using the UP or DOWN arrow keys. Should three channels be used, then the third channel would be set to .9999.

CHART PEN ZERO AND SPAN

- CHART PEN ZERO -
UP OR DOWN TO MOVE PEN

This screen calibrates the pen zero point on the chart paper to the zero of the input signal. **It is important that the pen be properly aligned and the 4 mA is being applied to the input before making this adjustment.** The zero value of the input signals of all the channels to be stacked must be input to the recorder when making this adjustment. For example, if the input signal is 4-20 mA for 0 to 100%, then 4 mA must be input to all channels to be summed to make the pen zero adjustment.

Press the UP or DOWN arrow keys to move the pen to the proper position. No changes will be made to the previously stored zero value unless the UP or DOWN arrow keys are pressed. So if the user is stepping through the program to access another programming screen, the input does not need to be at the zero value if the UP or DOWN arrow keys are not pressed. When pressing the UP or DOWN arrow keys the display will indicate the direction of the pen movement. Once the pen is positioned to zero on the chart, then press the ENTER key. **Be sure to press the ENTER key before changing the input signal.** The following screen will appear:

- CHART PEN SPAN -
UP OR DOWN TO MOVE PEN

This screen calibrates the pen span point on the chart paper to the span of the input signal. The span value of the input signal for all channels to be summed must be input to the recorder when making this adjustment. For example, if the input signal is 4-20 mA for 0 to 100%, then 20 mA must be input to all channels to be summed, to make the pen span

adjustment.

Press the UP or DOWN arrow keys to move the pen to the proper position. No changes will be made to the previously stored span value unless the UP or DOWN arrow keys are pressed. So if the user is stepping through the program to access another programming screen, the input does not need to be at the span value if the UP or DOWN arrow keys are not pressed. When pressing the UP or DOWN arrow keys the display will indicate the direction of the pen movement. Once the pen is positioned to span on the chart, press the ENTER key. **Be sure to press the ENTER key before changing the input signal.** The next screen to appear will be the Relay Assignment screen.

-RELAY ASSIGNMENT-
RELAY 01 => LO

This screen allows the assignment of the relays for any of the alarm functions. The available alarm functions are:

- IN - Loss of input signal
- LO - Low alarm trip
- HI - High alarm trip
- CHT - Completion of one chart rotation
- INT - Contact integrator pulse
- EE - Failure of EEPROM
-
-

There are two blank alarms for future use which are represented by the dashed lines. Press the UP or DOWN arrow keys to select the desired alarm and then press the ENTER key. The second relay assignment will appear with the same alarm functions to be selected as above. After assigning the desired alarm the following screen will appear:

CONTACT INTEGRATOR
0000 X 1,000 GAL

This screen allows the setting of the contact integrator to the desired amount of totalized flow for each pulse output. For example, if the desire is to have a contact closure every 10,000 gallons, then the number to be entered is 0010.

Press the UP or DOWN arrow keys to change the value of the digit and the RIGHT arrow key to move the cursor under the digit to be changed. Press the ENTER key. The following screen will appear:

INTEGRATOR PULSE WIDTH
ON FOR 0000 X .0328 SEC.

This screen allows the setting of the pulse width of the contact integrator output pulse. If the device being connected to the contact integrator output requires an input

with a pulse width of 50 milliseconds, then the multiplier would be set to 2. Use the RIGHT arrow key to move the cursor under the digit to be changed and the UP or DOWN arrow keys to set the desired value and press the ENTER key. The following screen will appear:

SET POINT ADJUSTMENT
HI ALARM = 99 PERCENT

This screen allows the setting of the High and Low alarm set points. Press the UP or DOWN arrow keys to the desired value and then press the ENTER key. The LO alarm screen set point will appear. Follow the same procedure above to set the Low alarm. The following screen will appear:

SETPOINT ADJUSTMENT
HYSTERESIS = 03 PERCENT

This screen sets the hysteresis for the High and Low alarm set points. If the High alarm is set for 60 percent and the hysteresis is 3 percent, then the High alarm will trip closed at 63 percent and open at 57 percent.

Press the UP or DOWN arrow keys to the desired value and press the ENTER key. The following screen will appear:

PRESS UP FOR 4-20
CURRENT CALIBRATION

This screen allows the entry into the calibration of the retransmitted 4-20 mA output. Press the UP arrow key to enter into the current calibration. The following screen will appear:

4-20 CURRENT OUT
ZERO WORD=3000

This screen allows the setting for the Zero output of the 4-20 mA current output circuit for 4 mA. Connect a current meter to the output terminals and monitor the current output. The Zero word is a four digit word with the digit to the far left being the coarse adjustment and digits moving to the right being the finer adjustments. Press the RIGHT arrow key to move the cursor under the desired digit for adjustment and press the UP or DOWN arrow keys to adjust the output to the proper value. Press the ENTER key to store the new value. The following screen will appear:

4-20 CURRENT OUT
SPAN WORD=A235

This screen allows the setting of the Span output of the 4-20 mA current output circuit for 20 mA. Connect a current meter to the output terminals and monitor the current output. The Span word is a four digit word with the digit to the far left being coarse adjustment and digits moving to the right being the finer adjustments. Press the RIGHT arrow key to move the cursor under the desired digit for adjustment and press the UP or DOWN arrow keys to adjust the output to the proper value. Press the ENTER key to store the new value. The following screen will appear:

-STORING PARAMETERS-
PARAMETERS>PROGRAMMED

This screen indicates that the new parameters have been stored in the recorder. The display will then return to the normal operating screen. This completes the Calibration Section.

OPTION (FOR FLOW UNITS SCREEN)

Selecting OPTION in the Flow Units screen allows the entering of any three letter label for special engineering units. Press the ENTER key with OPTION selected and the following screen will appear:

MEASUREMENT UNITS
OPTION INITIALS=AAA

There will be a cursor under the first letter. Use the UP or DOWN arrow keys to select the desired letter. Press the RIGHT arrow key to move the cursor to the second and third letter and select the desired letter. Press the ENTER key to enter the OPTION INITIALS. The following screen will appear:

DISPLAY FLOW LABEL AND
TOTALIZER ? YES

This screen asks if the FLOW label is to be displayed on the normal operating screen. If the recorder is to be used to record temperature or some other measurement not related to flow or requires totalization, then selecting NO will remove the FLOW label and the totalizer value from the screen. Use the UP or DOWN arrow keys to select YES or NO and press the ENTER key. The following screen will appear:

UNIT MULTIPLIER
AAA X 1,000

This screen allows the selection of the desired flow rate multiplier. Press the UP or DOWN arrow keys to select the desired multiplier and then press the ENTER key. The following screen will appear:

FULLSCALE UNITS=AAA
FULLSCALE = 0000 X 1,000

This screen allows the entering of the full scale flow rate desired. Press the UP or DOWN arrow keys to select the desired value and the RIGHT arrow key to move the cursor under the digit to be changed. After the desired value is selected, press the ENTER key. If NO was selected, the next screen will be the Chart Revolution Speed screen. Go back to Page 11. If YES was selected, the following screen will appear:

TOTALIZER UNIT
UNIT INITIALS=AAA

This screen allows the entering of the desired totalizer unit label. Press the UP or DOWN arrow keys to select the desired letter and the RIGHT arrow key to move the cursor under the letter to be changed.

After the desired letters are selected press the ENTER key. The following screen will appear:

TOTALIZER MULTIPLIER
X 1,000

This screen allows the selection of the desired totalizer multiplier. Press the UP or DOWN arrow keys to select the desired multiplier and then depress the ENTER key. The following screen will appear:

-TOTALIZER WORD-
0000 0000 0000

The Totalizer Word is required to setup the time base to properly totalizer in the selected option units. The totalizer word is defined as follows:

$$\frac{\text{Totalizer Multiplier}}{\text{Max. Flow in Units/Sec}} \times 2,000,000 = \text{HEX}$$

EXAMPLE:

Maximum flow = 1800 x 1 BPM (Barrels/min)
Totalizer multiplier = BAR x 100
Totalizer Word =
(100/(1800/60))x2,000,000 = 6666666.6

Converted to Hexadecimal = 65B9AA (see the Decimal to Hexadecimal Conversion Section).

The TOTALIZER WORD is 0000 0065 B9AA

Note: The totalizer word must be greater than Hex 1000.

Use the UP and DOWN arrow keys to change each digit to the required value and the RIGHT arrow to move the cursor. The ENTER key must be depressed after each set of four digits. Return to Page 10 where the next screen will be the Chart Speed selection.

ERROR SCREENS

There are several Error Screens that will be displayed by the recorder if the microprocessor detects errors in the values programmed into the recorder.

-CHART PEN ZERO-
<INPUT ZERO ERROR>

OR

-CHART PEN SPAN-
<INPUT SPAN ERROR>

If either of the two above Error Screens appear during the chart pen adjusting procedure, one of the following problems probably occurred:

1. There was not a 4-20 mADC analog signal to the recorder analog channel you selected while adjusting the chart zero span.
2. An analog input signal channel was selected without adjusting the chart pen zero and span of this channel.

3. The Zero and Span of the recorder have been adjusted too close to the same input value.

To correct these errors, readjust the Chart Pen Zero and Span while inputting the 4-20 mADC analog signal to the proper selected recorder channel. Refer to the Calibration Mode Section of this manual.

-STORING PARAMETERS-
<TOTALIZER WORD ERROR>

If the above Error Screen appears after pressing the ENTER key to store the calibration adjustments, this indicates that you have selected a totalizer multiplier that is too low for your selected flow rate. To correct this error, re-enter the Calibration Mode and when the Totalizer Multiplier Screen appears, increase the totalizer multiplier and press the ENTER key. Then press the MENU key to store the new multiplier and return to the normal operating screen.

If you still have a Totalizer Word Error message in the Storing Parameters screen, repeat the above procedure until the error is not present.

HEXADECIMAL SYSTEM

The purpose of the hexadecimal number system is simply to reduce the number of units necessary for representing any given numerical figure, thereby reducing the amount of space in memory necessary to retain it.

Herein, a decimal (normal) number is converted to a correct hexadecimal number which consists of fewer characters.

The hexadecimal number system consists of only 16 characters which are shown below by the boldface characters.

0	=	0
1	=	1
2	=	2
3	=	3
4	=	4
5	=	5
6	=	6
7	=	7
8	=	8
9	=	9
10	=	A
11	=	B
12	=	C
13	=	D
14	=	E
15	=	F

These characters may be arranged in various sequences to produce an infinite number of representations of decimal numbers. For example: 6D4C = 27,980.

CONVERSION OF DECIMAL WHOLE NUMBER TO HEXADECIMAL NUMBER

1. Divide the decimal number by 16.

Example: $57420/16 = 3588.75$

2. Multiply only the fractional part of the product by 16 to arrive at the first character in the hexadecimal equivalent. Remember, all numbers produced in this step are shown above. Also note that the product may have no fraction (.000) which would result in zero as the hexadecimal number.

Example: $.75 \times 16 = 12 = \mathbf{C}$

3. Divide the whole number portion of the product by 16 thereby producing yet another number.

Example: $3588/16 = 224.25$

4. Repeat steps 2 and 3 in a cyclical fashion until the numerator to be divided in Step 3 is less than 16. At that point, the numerator represents the final character in the hexadecimal sequence.

EXAMPLE: Convert 57,420 into a hexadecimal number:

- 1.) $57,420/16 = 3588.75$
- 2.) $.75 \times 16 = 12 = \mathbf{C}$
- 3.) $3,588/16 = 224.25$
- 2.) $.25 \times 16 = \mathbf{4}$
- 3.) $224/16 = 14.00$
- 2.) $.00 \times 16 = \mathbf{0}$
- 3.) $14 = \mathbf{E}$

$57,420 = \mathbf{E04C}$

CONVERSION OF A WHOLE HEXADECIMAL NUMBER TO A DECIMAL NUMBER

1. Multiply the left most character in the hexadecimal number by 16.
Example: $\mathbf{E} = 14 \times 16 = 224$
2. Add to the product previously found the value of the next character.
Example: $224 + 0 = 224$
3. Multiply the previously found product by 16.
Example: $224 \times 16 = 3584$
4. Repeat steps 2 and 3 in a cyclical fashion until you have added the last hexadecimal character. Do not multiply beyond that point.

EXAMPLE: Convert E04C into a decimal number.

1.) $\mathbf{E} = 14; 14 \times 16 = 224$

2.) $224 + 0 = 224$

3.) $224 \times 16 = 3584$

2.) $3584 + 4 = 3588$

3.) $3588 \times 16 = 57,408$

4.) $57,408 + 12 = 57,420$

$$\mathbf{E04C} = 57,420$$

INSERT DWG 600663-9999 3050 RECORDER ASSY DWG

CHART PLATE ASSEMBLY PARTS LIST

ITEM	PART NUMBER	DESCRIPTION	U/M	QTY
12	543744-0001	SERVO MECH ASSY	EA	1.0
13	400001-0088	HEX NUT 2-56 X 7/16	EA	4.0
14	430002-0106	FLAT WASHER	EA	4.0
15	501401-0001	SPACER #2	EA	2.0
16	151960-0001	PCB MOTHER BOARD	EA	1.0
17	510031-0131	SPRING	EA	1.0
18	543075-0001	LCD DISPLAY	EA	1.0
19	500050-0043	SPACER	EA	4.0
20	410001-0007	HEX NUT 6-32	EA	13.0
22	512645	HINGE	EA	1.0
23	512594	CHART PLATE	EA	1.0
24	501078	MEMBRANE SWITCH	EA	1.0
27	540769	CHAIN ASSY	EA	1.0
29	400002-0015	SCREW 6-32 X 5/16	EA	11.0
30	400005-0017	SCREW 2-56 X 3/16	EA	2.0
31	501132-0005	CONNECTOR HOUSING	EA	1.0
32	501425-0002	STEPPER MOTOR	EA	1.0
33	500050-0015	SPACER #6	EA	2.0
34	400006-0025	SET SCREW 4-40 X 3/16	EA	1.0
35	524720	CHART CLAMP BODY	EA	1.0
36	400006-0071	SET SCREW 5-40 X 5/16	EA	1.0
37	512610	COVER W/LOGO	EA	1.0
38	524743	CHART KNOB	EA	1.0
39	400002-0010	SCREW 6-32 X 5/8	EA	2.0
40	512114	PEN ARM	EA	1.0
41	500638-0003	ON/OFF SWITCH	EA	1.0
42	430002-0105	FLAT WASHER	EA	5.0
43	500983-0001	SNAP FASTENER	EA	5.0
44	512224	PEN REPLACEMENT DECAL	EA	1.0
45	500724-0001	RED FIBER TIP PEN	EA	2.0
46	440005	RETAINER	EA	2.0
47	501276-0002	SCREW	EA	2.0
48	500146-0005	LOCTITE	EA	0.01
49	501239	BELT CLAMP	EA	1.0
50	525733	PEN LIFTER	EA	1.0
52	430003-0002	WASHER	EA	11.0
79	500014	ON/OFF NAMEPLATE	EA	1.0

CASE ASSEMBLY PART LIST

51	512599	CASE	EA	1.0
52	430003-0002	WASHER	EA	1.0
53	500023-0037	TERMINAL BLOCK	EA	1.0
54	512633	MTG BRACKET	EA	4.0
55	400013-0064	MTG SCREW 5/16-18 X 4.5	EA	4.0
56	501275-0001	CLIP	EA	2.0

TROUBLESHOOTING DIAGRAM

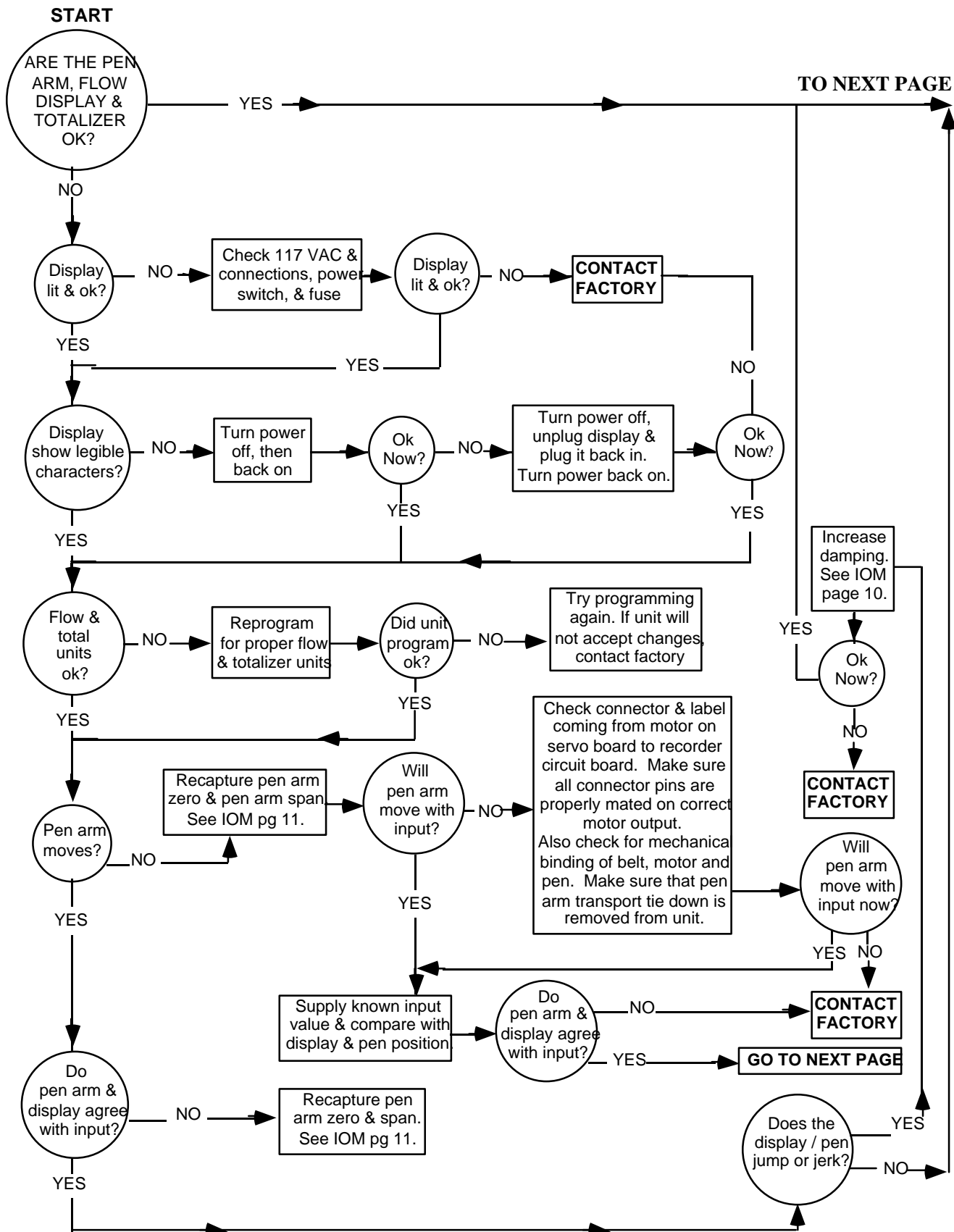

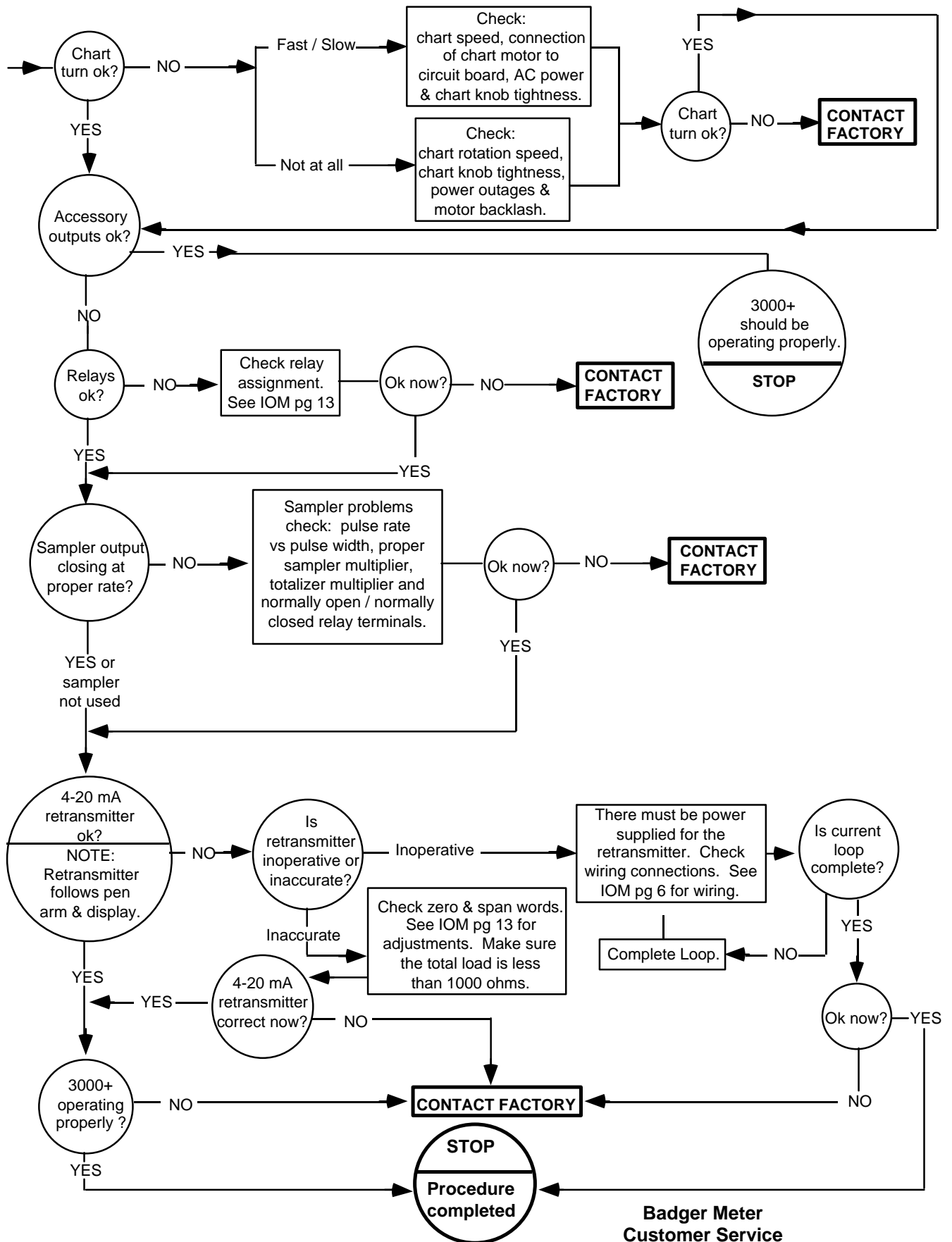

**Badger Meter
Customer Service
(918) 836-8411**

INSERT 3050 RECORDER WIRING DIAGRAM PICTURE

WARRANTY

Badger warrants meters and parts manufactured by it and supplied hereunder to be free from defects in materials and workmanship for a period of 18 months from date of shipment or 12 months from date of installation, whichever period shall be shorter. If within such period any meters or parts shall be proved to Seller's satisfaction to be defective, such meters or parts shall be repaired or replaced at Seller's option. Seller's obligation hereunder shall be limited to such repair and replacement and shall be conditioned upon Seller's receiving written notice of any alleged defect within 10 days after its discovery and, at Seller's option, return of such meters or parts f.o.b. to Seller's factory. THE FOREGOING WARRANTY IS EXCLUSIVE AND IN LIEU OF ALL OTHER EXPRESS OR IMPLIED WARRANTIES WHATSOEVER INCLUDING BUT NOT LIMITED TO IMPLIED WARRANTIES (EXCEPT OF TITLE) OF MERCHANTABILITY AND FITNESS FOR A PARTICULAR PURPOSE. Badger shall not be liable for any defects attributable to acts or omissions of others after shipment, nor any consequential, incidental or contingent damage whatsoever.

NUCLEAR DISCLAIMER

Equipment sold by Badger Meter, Inc. Is not intended for use in connection with any nuclear facility or activity unless covered by a specific quotation where the conditions of such usage will be detailed. If equipment is used in a nuclear facility or activity without a supporting quotation, Badger Meter disclaims all liability for any damage, injury or contamination, and the buyer shall indemnify and hold Badger Meter, its officers, agents, employees, successors, assigns and customers, whether direct or indirect, harmless from and against any and all losses, damages or expenses of whatever form or nature (including attorney's fees and other costs of defending any action) which they, or any of them, may sustain or incur, whether as a result of breach of contract, warranty, tort (including negligence), strict liability or other theories of law, by reason of such use.